

Nice

CE

SPY550
SPY650
SPY650 HS
SPY800
SPY800/V1

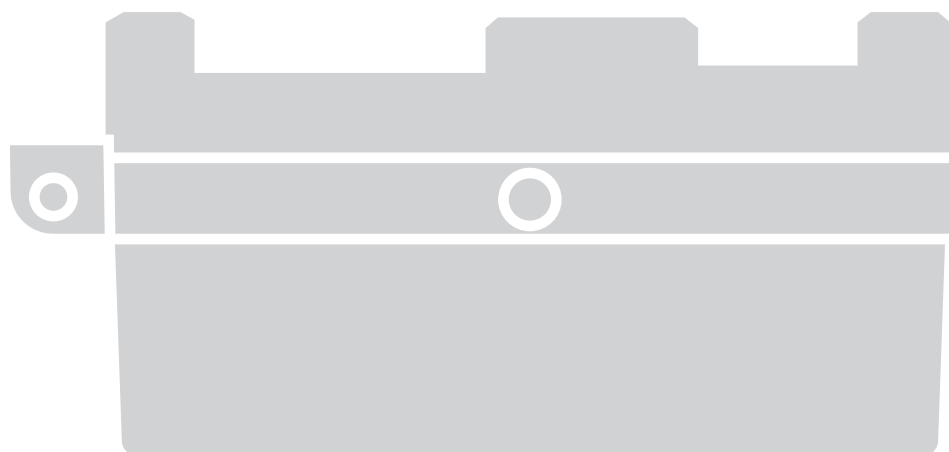

Garage door opener

EN - Instructions and warnings for installation and use

Nice

GENERAL WARNINGS: SAFETY - INSTALLATION - USE	3
1 - PRODUCT DESCRIPTION AND INTENDED USE	4
2 - APPLICATION LIMITS	4
3 - INSTALLATION	5
3.1 - Gearmotor installation	5
3.2 - Installation of the control unit box	10
4 - TESTING AND COMMISSIONING	13
4.1 - Testing	13
4.2 - Commissioning	13
5 - PROGRAMMING	14
5.1 - Control unit quick set-up	15
5.2 - Standard Setup	16
5.3 - Device Acquisition	16
5.4 - Acquisition of Opening and Closing Positions	16
5.5 - Deletion of parameters memory	16
5.6 - Deletion of radio codes memory	16
5.7 - Deletion of total memory	17
5.8 - Parameter programming (ON-OFF)	17
5.8.1 - 1st level Parameters	17
5.8.2 - Level 2 parameters (ADJUSTABLE PARAMETERS)	17
5.9 - Integraradio receiver	19
5.10 - Radio diagnostics during memorisation or deletion of radio transmitters	20
5.11 - Remote memorisation	20
5.12 - Radio quick set-up	20
5.13 - External radio receiver (SPYBOX B only)	21
5.13.1 - Memorisation of radio transmitters	21
6 - FURTHER DETAILS	22
6.1 - Connecting an Oview	22
6.2 - Adding or removing BlueBUS devices (SPYBOX B and SPYBOX B HS only)	22
6.3 - STOP input connection	23
6.4 - Power for external devices	23
6.5 - Spylight	23
6.6 - Back-up battery model PS324 (only for SPYBOX B and SPYBOXB HS)	24
6.7 - Solemyo System (only for SPYBOX B)	24
6.8 - Safety device for pedestrian door	25
6.9 - "Move anyway" function	26
6.10 - Diagnostics	26
6.10.1 - Control unit signals	26
6.10.2 - Signals for warning light, courtesy light or SPYLIGHT	27
7 - WHAT TO DO IF...	28
8 - DISPOSAL OF THE PRODUCT	29
9 - MAINTENANCE	29
10 - TECHNICAL SPECIFICATIONS	30
EU Declaration of Conformity	31
Operation manual (to be given to the final user)	33

GENERAL WARNINGS: SAFETY - INSTALLATION - USE (original instructions in Italian)

CAUTION Important safety instructions. Follow all instructions as improper installation may cause serious damage
CAUTION Important safety instructions. It is important for you to comply with these instructions for your own and other people's safety. Keep these instructions

- Before commencing the installation, check the "Technical characteristics", in particular whether this product is suitable for automating your guided part. If it is not suitable, DO NOT continue with the installation.
- The product cannot be used before it has been commissioned as specified in the chapter on "Testing and commissioning"

CAUTION According to the most recent European legislation, the implementation of an automation system must comply with the harmonised standards provided by the Machinery Directive in force, which enables declaration of the presumed conformity of the automation. Taking this into account, all operations regarding connection to the electricity grid, as well as product testing, commissioning and maintenance, must be performed exclusively by a qualified and skilled technician!

- Before proceeding with the installation of the product, check that all materials are in good working order and suited to the intended applications
- The product is not intended for use by persons (including children) with reduced physical, sensory or mental capacities, nor by anyone with insufficient experience or familiarity.
- Children must not play with the appliance
- Do not allow children to play with the fixed control devices of the product. Keep the remote controls out of reach of children.

CAUTION In order to avoid any danger from inadvertent resetting of the thermal cut-off device, this appliance must not be powered through an external switching device, such as a timer, or connected to a supply that is regularly powered or switched off by the circuit

- Provide a disconnection device (not supplied) in the plant's mains power supply, with a contact opening distance that permits complete disconnection under the conditions dictated by overvoltage category III
- Handle the product with care during installation, taking care to avoid crushing, denting or dropping it, or allowing contact with liquids of any kind. Keep the product away from sources of heat and naked flames. Failure to observe the above can damage the product, and increase the risk of danger or malfunction. If this should happen, stop installation immediately and contact Customer Service
- The manufacturer assumes no liability for damage to property, items or persons resulting from non-compliance with the assembly instructions. In such cases the warranty for material defects is excluded
- The weighted sound pressure level of the emission A is lower than 70 dB(A)
- Cleaning and maintenance to be carried out by the user must not be carried out by unsupervised children
- Before intervening on the system (maintenance, cleaning), always disconnect the product from the mains power supply and any backup batteries
- Check the system periodically, in particular all cables, springs and supports to detect possible imbalances, signs of wear or damage. Do not use if repairs or adjustments are necessary, since installation failure or an incorrectly balanced door may cause injury
- The packing materials of the product must be disposed of in compliance with local regulations
- The product must not be installed outdoors
- Keep an eye on moving doors and do not let anyone go near them until they have opened or closed fully
- Be careful when activating the manual release device, as an open door may fall suddenly due to weak or broken springs, or if it is unbalanced
- Every month, check that the drive motor reverses when the door encounters a 50 mm-high object placed on the ground. If necessary, readjust the door and check it again, as incorrect adjustment is potentially dangerous (for drive motors incorporating a trapping safety system that intervenes when the door's lower edge encounters an obstacle)
- If the power cable is damaged, it must be replaced by the manufacturer or the latter's technical assistance service, or by a similarly qualified person, in order to prevent any type of risk

INSTALLATION PRECAUTIONS

- Prior to installing the drive motor, check that the door is in good working order, correctly balanced and that it opens and closes properly
- Prior to installing the motor, remove all unnecessary cables or chains and deactivate any equipment – such as locking devices – not required for motorised operation
- Check that there are no points where trapping or crushing against fixed parts can occur when the moving section is in the fully open or closed position; adequately protect any such parts
- Install the manoeuvring assembly for manual release at a height below 1.8 m
NOTE: if removable, the manoeuvring assembly must be kept close to the door
- Make sure that the controls are at a safe distance from the moving parts, while allowing a good view of them.
Unless a switch is used, the controls should be installed at least 1.5 m off the ground and should not be accessible
- Permanently attach the trapping hazard warning labels in a highly visible location or near the fixed control devices (if present)
- Permanently attach the manual release label close to the manoeuvring assembly
- After installation, make sure that the motor prevents or stops door opening when the latter is loaded with a 20 kg weight secured to the centre of its bottom edge (for drive motors that can be used with doors having opening widths exceeding 50 mm)
- After installation, make sure that the mechanism is properly adjusted and that the motor reverses when the door collides with a 50 mm-tall object placed on the ground (for drive motors incorporating a trapping safety system that intervenes when the bottom edge of the door encounters an obstacle);
Following installation, check and ensure that no door parts obstruct public roadways or pavements

1 PRODUCT DESCRIPTION AND INTENDED USE

SPY is a family of electromechanical gearmotors with separate control unit intended for automation of protruding or non-protruding spring or counterweight overhead doors (Fig. 1): for up-and-over garage door you must use the SPA5 accessory. The control unit incorporates a radio receiver 433.92 MHz with FLOR coding.

⚠ CAUTION! – All uses other than the intended use described and use in environmental conditions other than those described in this manual should be considered improper and forbidden!

2 APPLICATION LIMITS

Table 1: application limits refer to the size of the protruding or non-protruding sectional door or overhead door (Fig. 1).

Table 2: application limits refer to the daily use of the protruding or non-protruding sectional door or overhead door (Fig. 1).

Table 1 – Application limits

Model	Sectional doors		Non-protruding overhead doors (with accessory SPA5)		Protruding overhead doors (with accessory SPA5) or with springs (without SPA5)	
	width	height	width	height	width	height
SPY550 + 3.2 m guide	3.6 m	2.5 m	3.5 m	2.3 m	3.5 m	2.8 m
SPY550 + 4 m guide	2.8 m	3.3 m	2.6 m	3.1 m	2.9 m	3.5 m
SPY650 + 3.2 m guide	4.2 m	2.5 m	4 m	2.3 m	4 m	2.8 m
SPY650 + 4 m guide	3.2 m	3.3 m	3 m	3.1 m	3.3 m	3.5 m
SPY800 + 3.2 m guide	5 m	2.5 m	5 m	2.3 m	5 m	2.8 m
SPY800 + 4 m guide	3.8 m	3.3 m	3.7 m	3.1 m	4 m	3.5 m

Note: the measurements indicated in this table are indicative and serve only to make a rough estimate. The real suitability of SPY to automate a specific garage door depends on the balancing of the door, on the friction of the guides and other phenomena, including occasional ones such as wind pressure or the presence of ice which could obstruct the movement.

⚠ Caution! Any other use or use with dimensions greater than specified is non-conforming. Nice declines all liability for damage and injury resulting for non-conforming use.

Table 2 – Application limits

Model	Cycles		
	Time	Day	Consecutive
SPY550	20	200	8
SPY650	30	300	12
SPY800	30	300	12

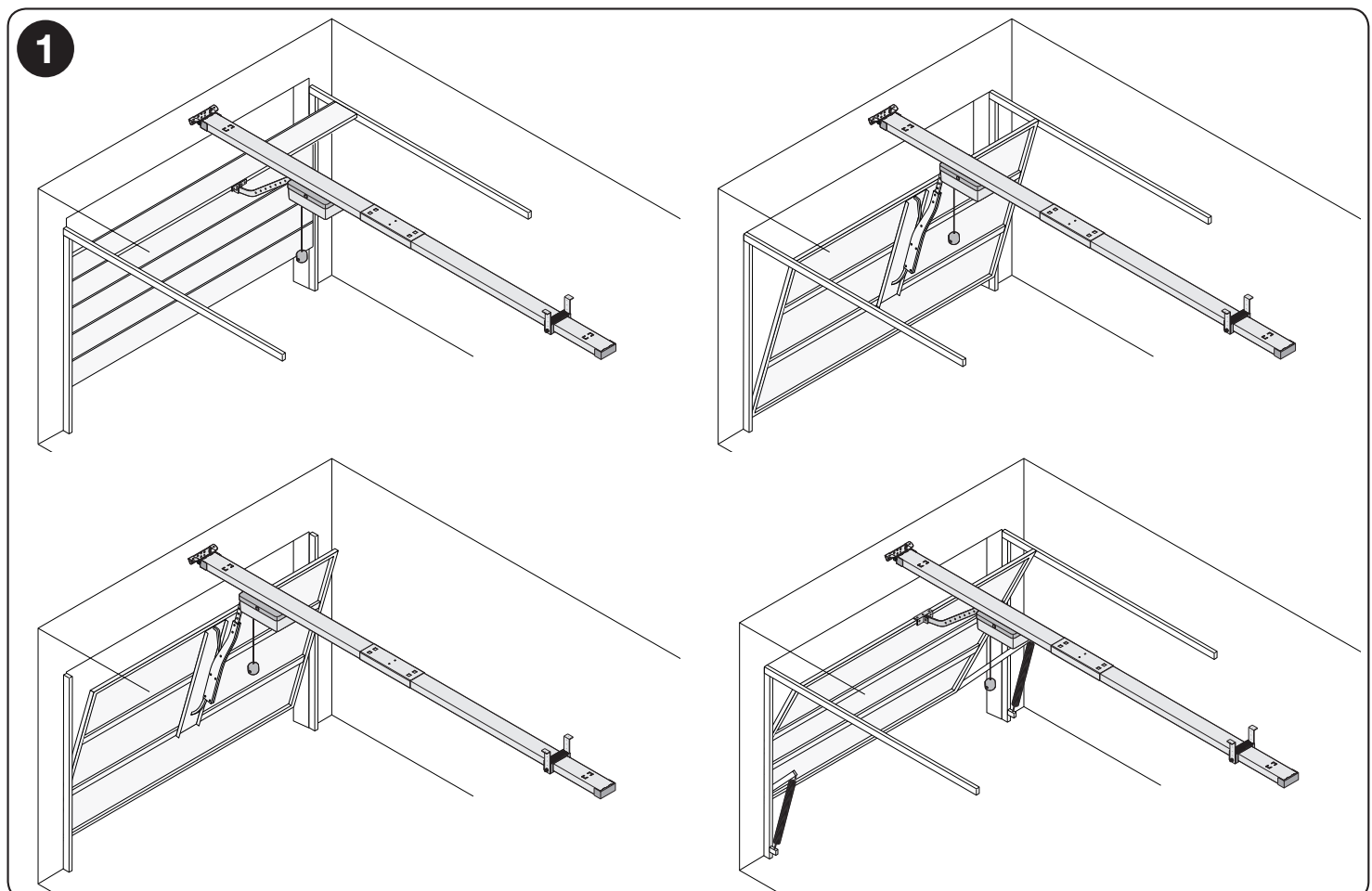

3 INSTALLATION

3.1 - Gearmotor installation

⚠ Important! Before installing the gearmotor check Chapter 2, the contents of the package to verify the materials (Fig. 2) and the overall dimensions of the gearmotor (Figs. 3-4).

⚠ Caution! The garage door must be able to move with ease. Limit to be complied with (according to EN12604):

- private use = 150 N maximum
- industrial/business use = 260 N maximum

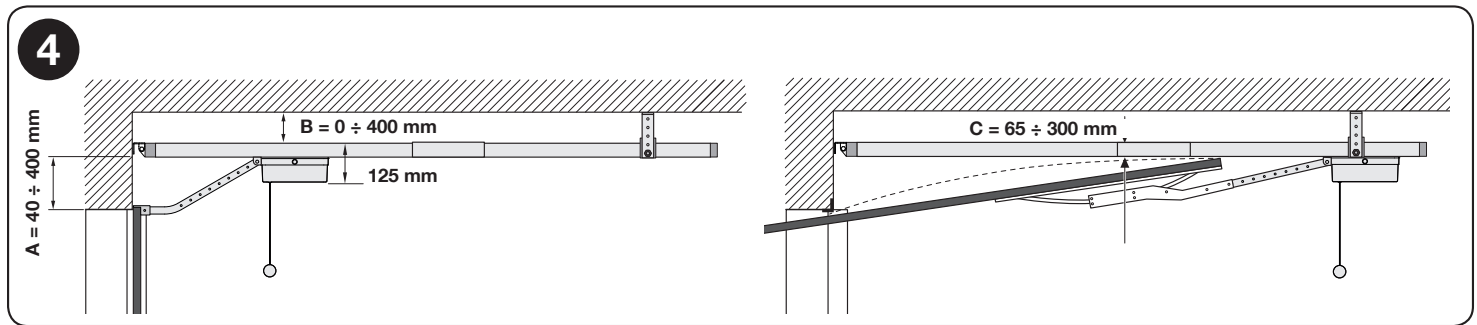
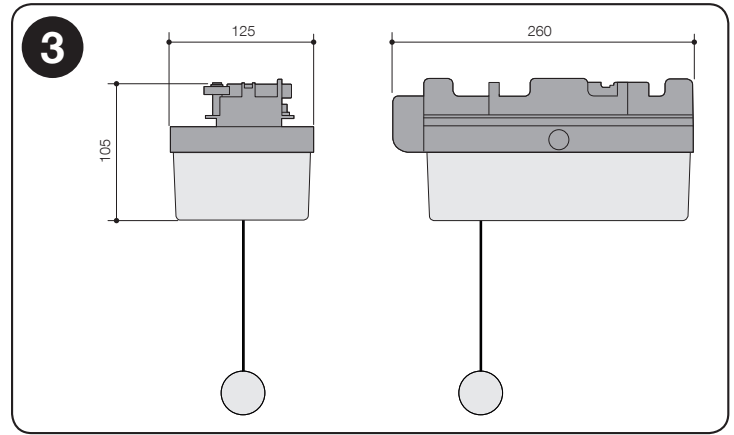
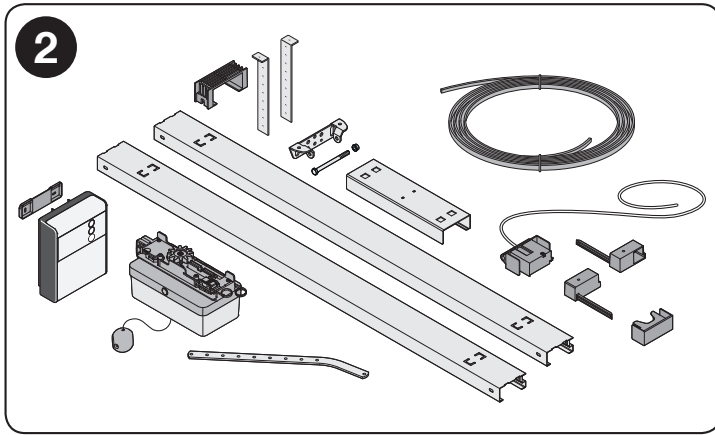
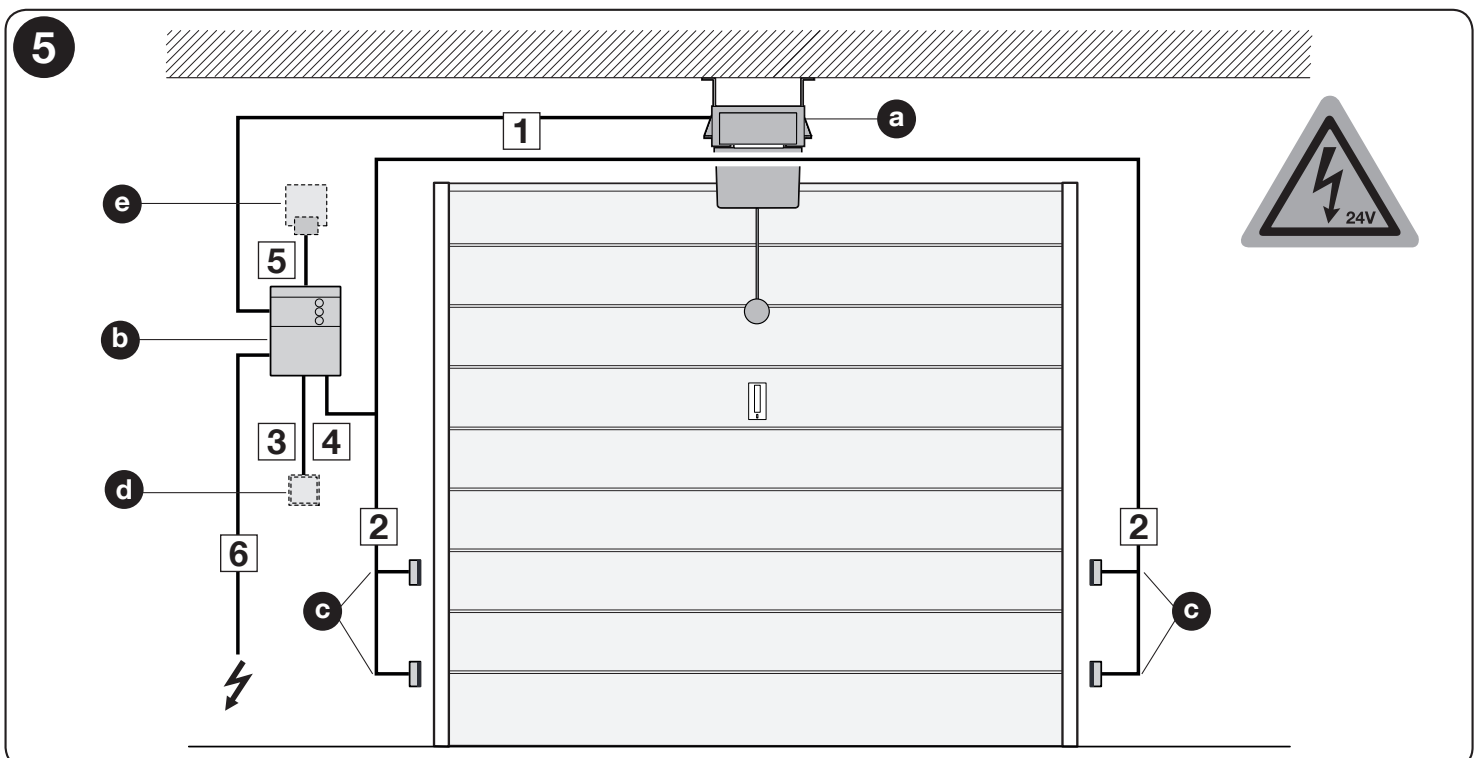

Fig. 5 shows the location of the components of a typical installation:

- a - gearmotor
- b - control unit
- c - photocells
- d - key-operated selector switch
- e - flashing light



⚠ The motor is powered at 24 V via the guide: the guide must be isolated from the garage door or other nearby devices.

01. 1 - join the two guides with special coupling
 2 - fold the tabs
 3 - check that the two guides are locked securely (without possibility of movement)

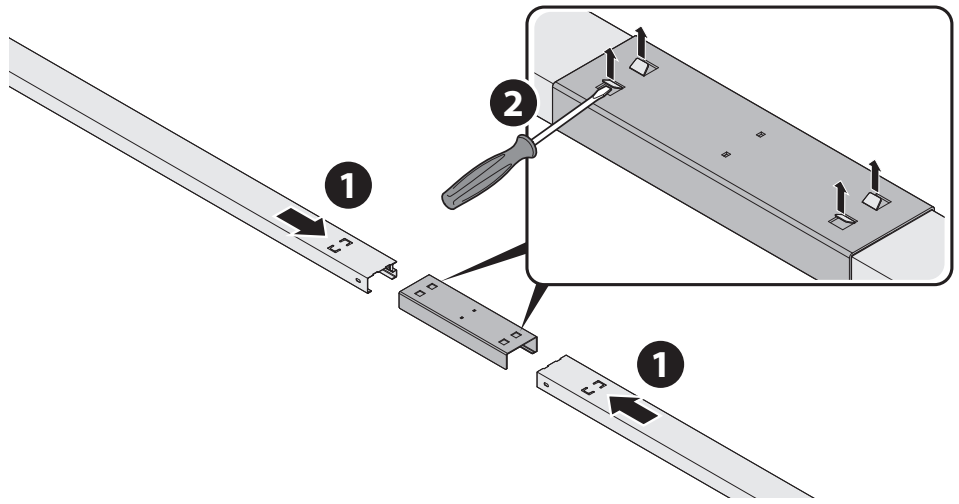

02. unwind the co-extruded item

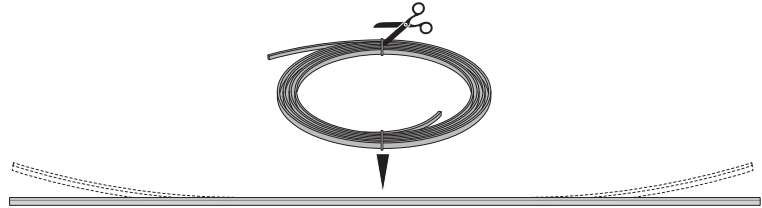

03. insert the co-extruded item into the guide as far as the stop. **Take care as regards the direction of insertion**

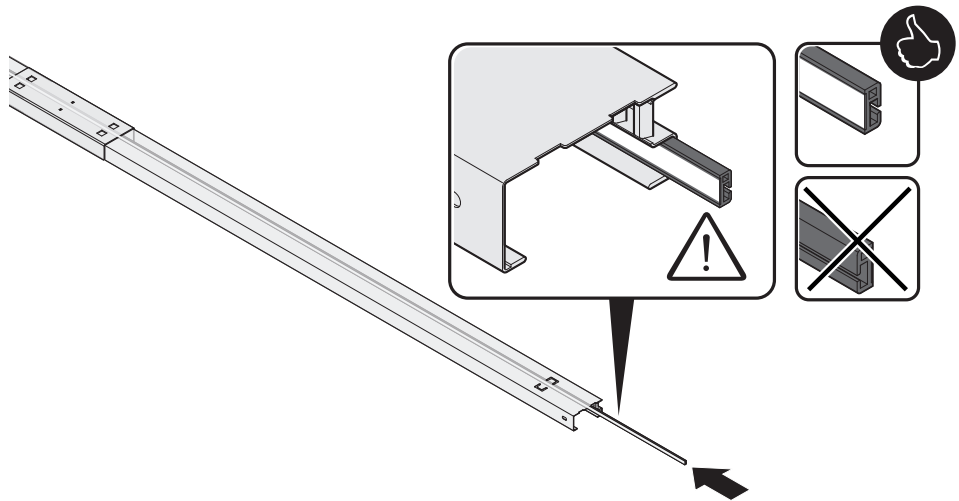

04. 1 - insert the right limit switch (opening)
 2 - insert the bracket for ceiling installation
 3 - insert the terminal element, while making sure that the side tabs slot correctly into their respective housings with a click

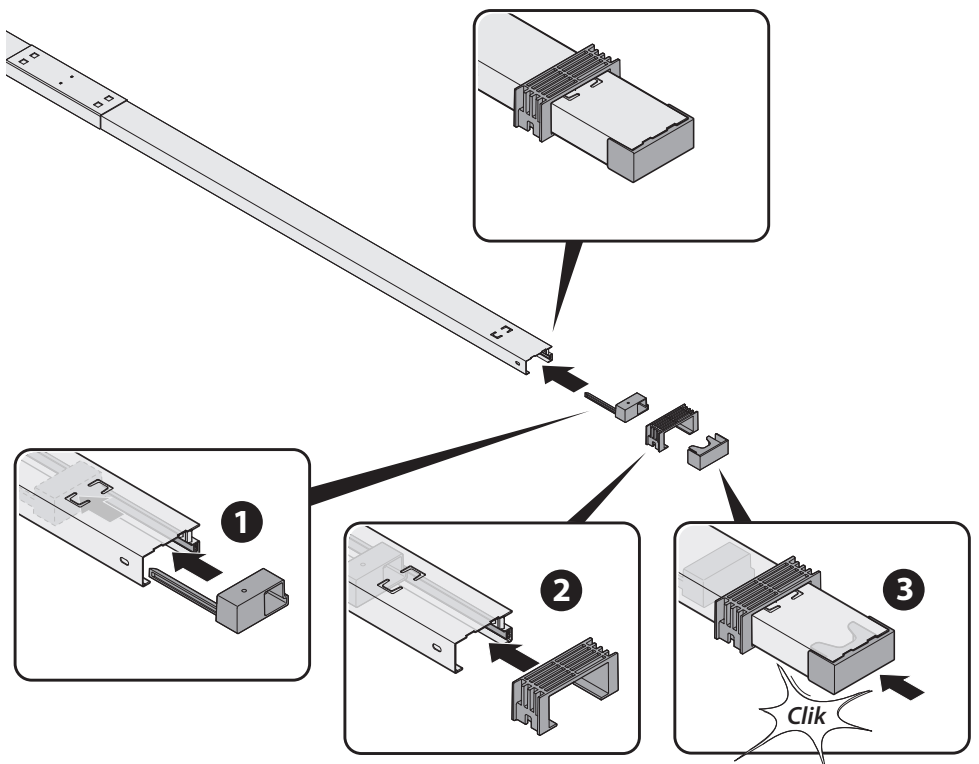

05. 1 - release the gearmotor with release cord
 2 - check that the gear wheel turns freely
 3 - insert the motor carriage into the guide (left): attention with the direction of insertion
 4/5 - slowly pull out the two straps making sure that they both make two clicks

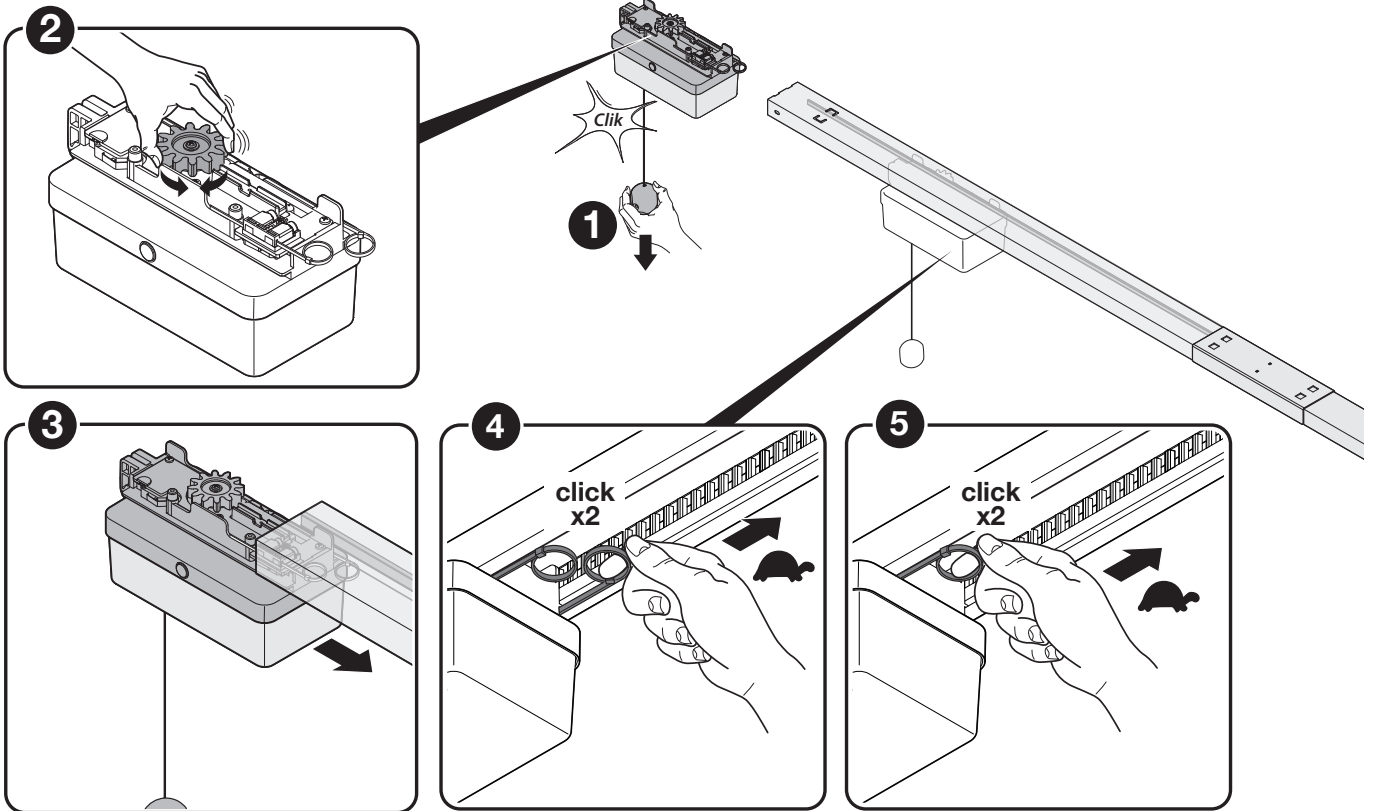

06. insert the left limit switch (closing)

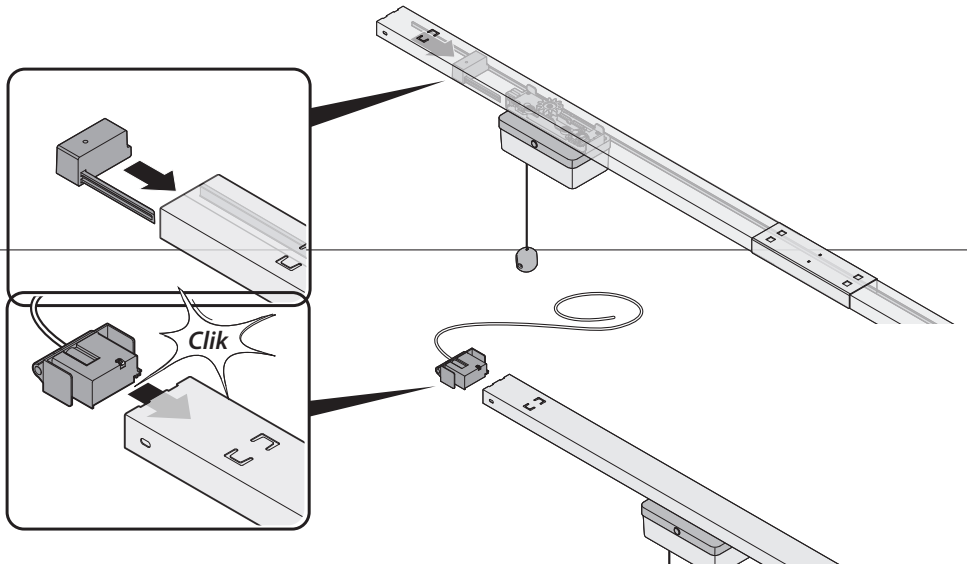

07. insert the terminal element with the wiring, while making sure that the side tabs slot correctly into their respective housings

⚠ CAUTION! – If necessary, re-insert the carriage motor, see Chapter 7 - Table 12 - “Problem Inserting motor carriage after performing maintenance”.

08. fix the garage door fixing bracket to the motor carriage

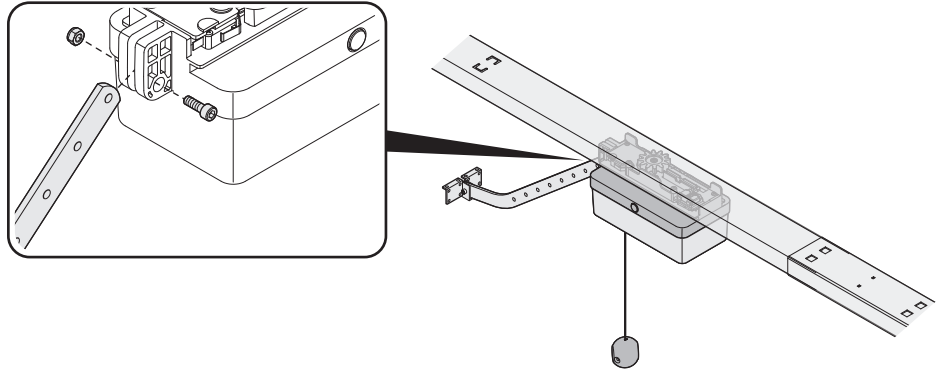

09. fix the bracket for fixing the guide to wall using special screws (* not included): Ø 6 mm

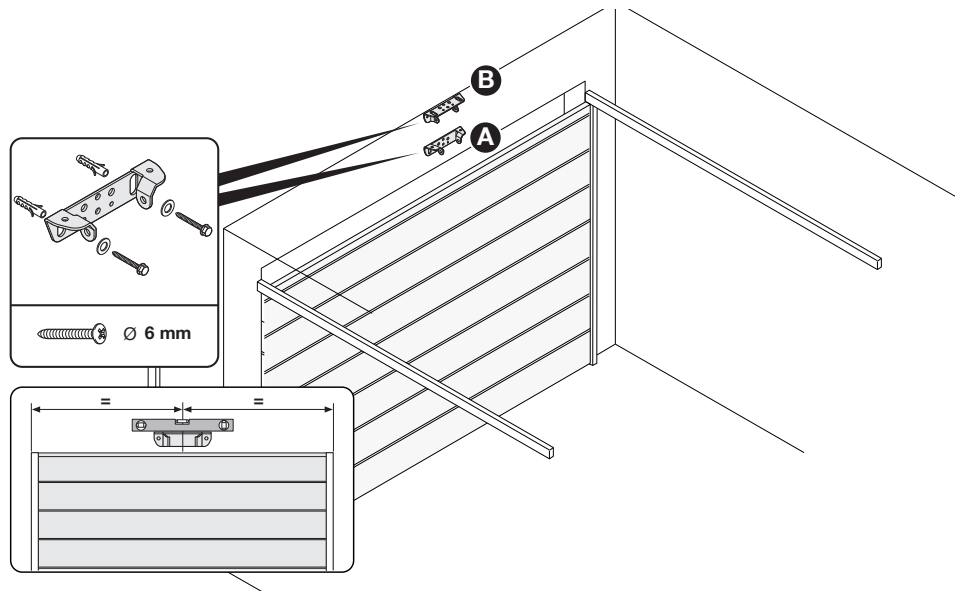

10. 1 - check the fixing dimensions (Fig. 4)
2 - fix the guide to the bracket with special screws

⚠ CAUTION! – When the guide is mounted on the wall at the side of the garage door, it **MUST NOT** be moved sideways to avoid moving the contacts in the plug with the cable.

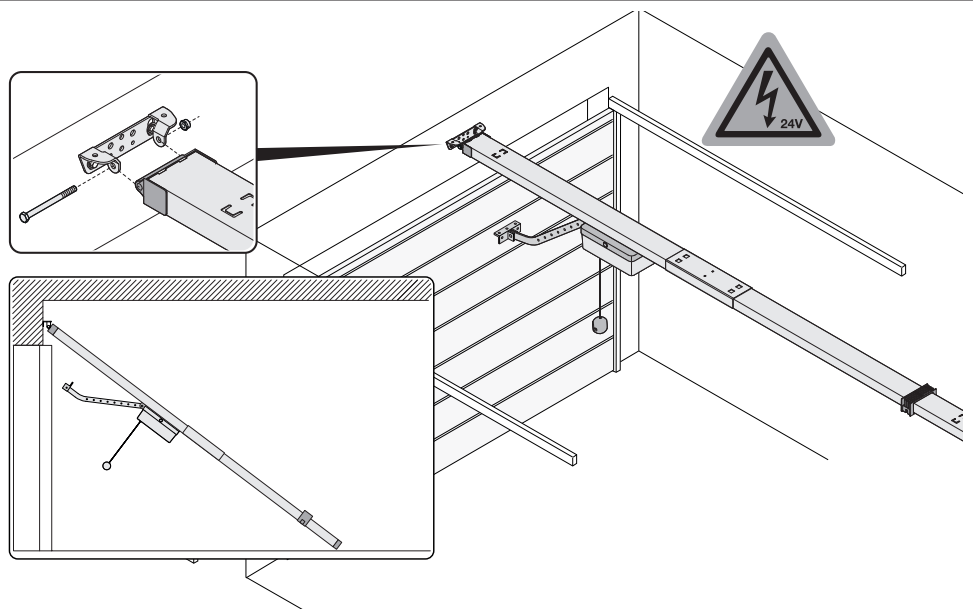

11. 1/2 - bring the guide parallel with the ceiling to attach the ceiling brackets: check that it is level
 3 - secure the ceiling brackets to the guide bracket using special screws
 4 - verify that the guide is centred with respect to the garage door and equidistant from the lateral guides
 5 - fix the brackets to the ceiling with special screws (* not included): \varnothing 6 mm
 6 - cut the two brackets exactly flush with the guide to prevent the motor carriage stopping during movement
 7 - fasten the bracket to the garage door definitively with special screws (not included)

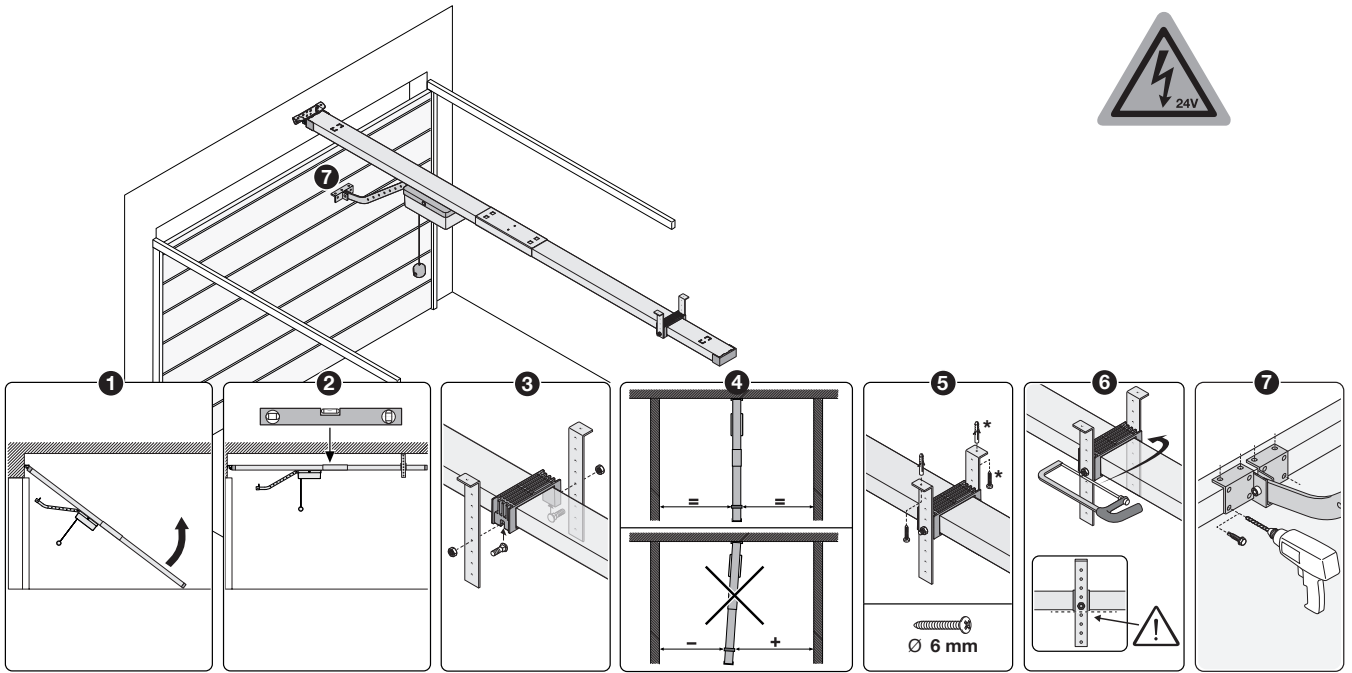

12. adjusting the limit switches
 A - tighten the special screw of the left-hand limit switch (closing)
 B - tighten the special screw of the right-hand limit switch (opening)

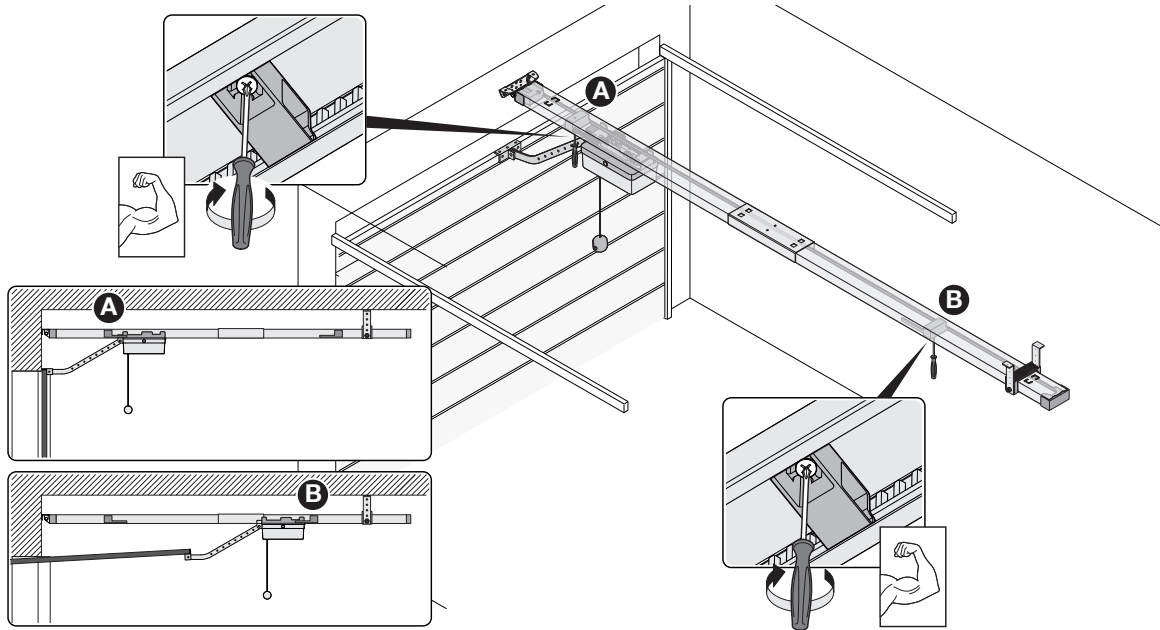

3.2 - Installation of the control unit box

⚠ Important! – Before installing the control unit box check the electrical connections in Fig. 5 and Table 3.

⚠ Danger from light emissions! – Looking at LED lights from close up and for prolonged periods can cause dazzling. It may temporarily reduce eyesight and cause accidents. Avoid looking at LEDs directly.

Table 3 - Types of electrical cable (see fig. 5)

	Clamp	Type of cable	Maximum length	Function
1	MOTOR (a)	2 x 1 mm ² (included)	5 m	24 V DC power to the guide
2	INP 2 (PHOTO/OPEN)	2 x 0.5 mm ²	20 m	Reconfigurable input 24VDC. It is factory configured as: - NC input with PHOTO operation in closing (SPYBOX) - NA input with OPEN operation (B SPYBOX)
	BLUEBUS	2 x 0.75 mm ²	20 m	Input for Bluebus devices. Warning - Connect devices in parallel
3	INP 1 (SbS)	2 x 0.5 mm ²	20 m	Reconfigurable input 24VDC. It is configured as NA input with SbS function
4	STOP	2 x 0.5 mm ²	20 m	Input for the connection of a STOP button or sensitive edge of the 8K2 resistive type. The input is with self-recognition with possibility NA, 8K2, NC *
5	OUT1 (FLASH)	2 x 0.5 mm ² (SPYBOXB / SPYBOX)	20 m	Output for connection of a flashing light (12 VDC - 21W or 24 VDC - 25 W programmable) or for connecting other devices with voltage 24 VDC - 25W max
		RG58 (SPYBOXB)	10 m	
6	POWER 230 VAC 50/60Hz	3 x 1 mm ² (not supplied)	-	Control unit power

* If you use a category B resistive sensitive edge (according to EN13849-1,-2) to limit the force of impact (according to CAT 2 and Performance Level C) you need to activate parameter L5 (level one programming) and perform search of devices

- 01.**
- 1 - open the cover: loosen the screw and pull downwards until you hear a click
 - 2 - prepare the routing for electric cables through the slot or cable glands
 - Slot: you must break the knock-outs with a screwdriver
 - Cable glands: it is necessary to make a hole with a drill and fasten the cable glands

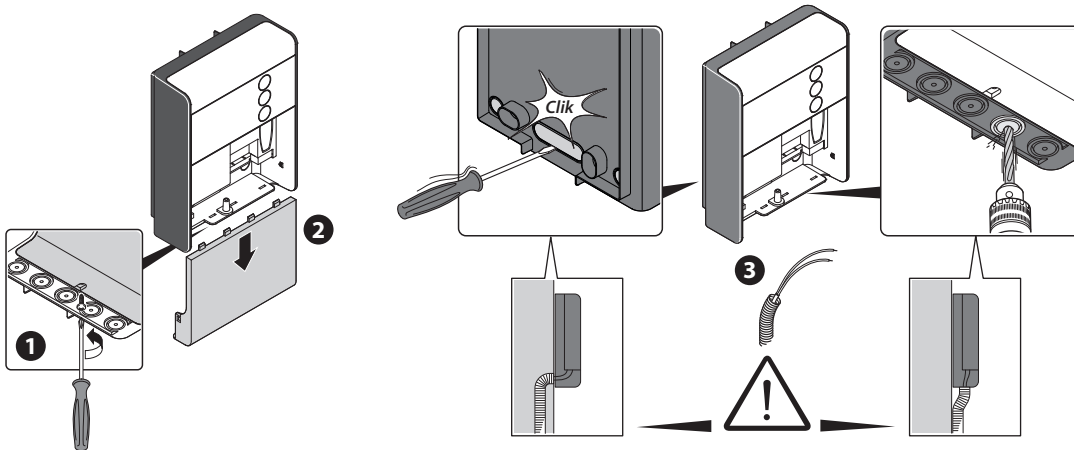

- 02.**
- 1 - install the bracket to the wall with special screws and wall plugs (not included: Ø 4 mm), where the control unit box needs to be fixed
 - 2 - attach the box to the bracket

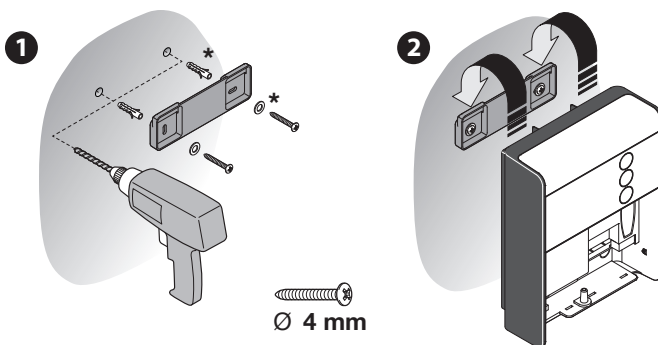

- 03.**
- 1 - mark the points to attach the bottom of the box
 - 2 - remove the box from the bracket and put it to one side
 - 3 - drill the holes with the drill
 - 4 - attach the box to the bracket and fix the bottom with the special screws (5)

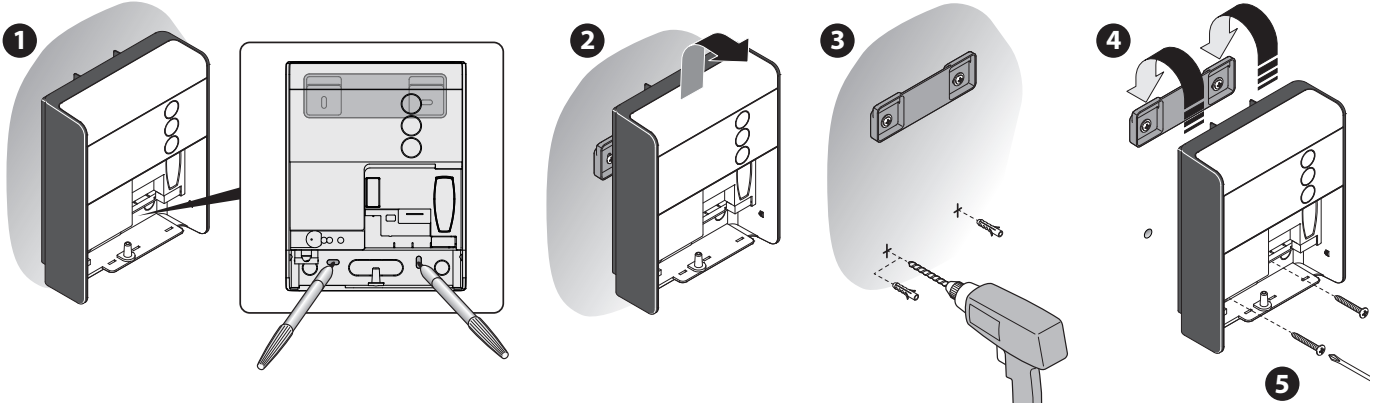

- 04.**
- 1 - connect the power cables of the motor and accessories (depending on the control unit model)
 - 2 - connect the power cable

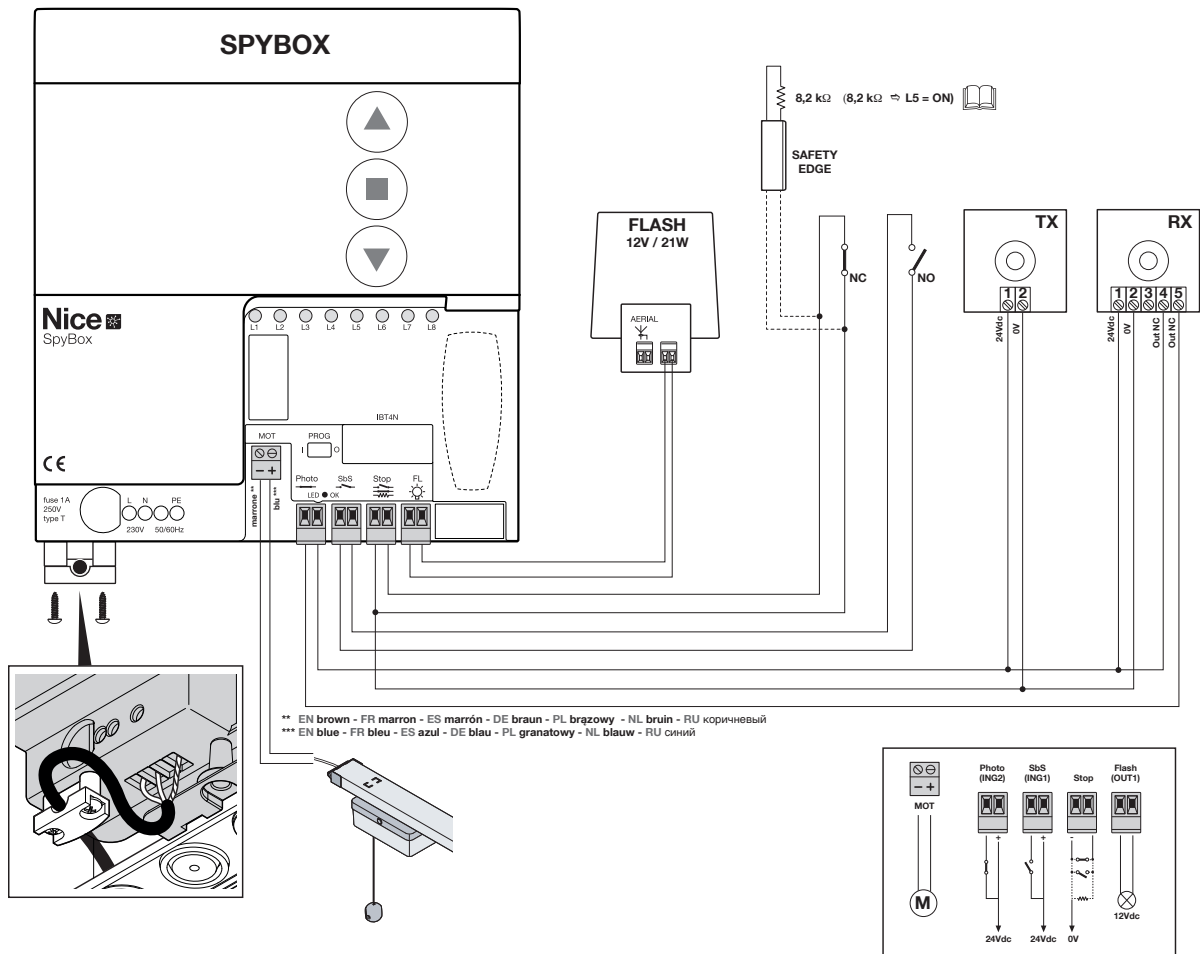

- Provide a disconnection device (not supplied) in the plant's mains power supply, with a contact opening distance that permits complete disconnection under the conditions dictated by overvoltage category III
- Before intervening on the system (maintenance, cleaning), always disconnect the product from the mains power supply and any backup batteries

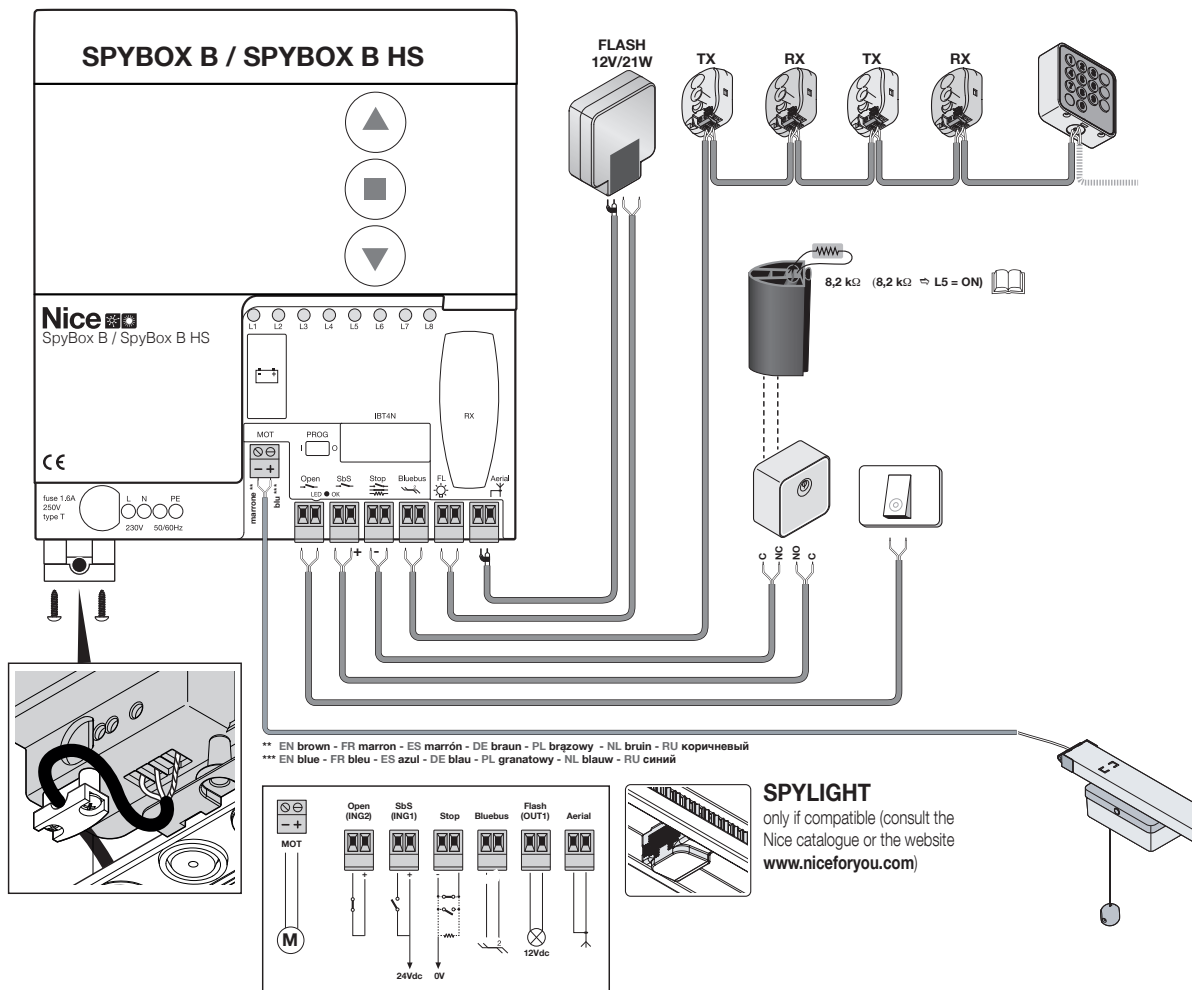

05. after the programming, close the lid with the special screw

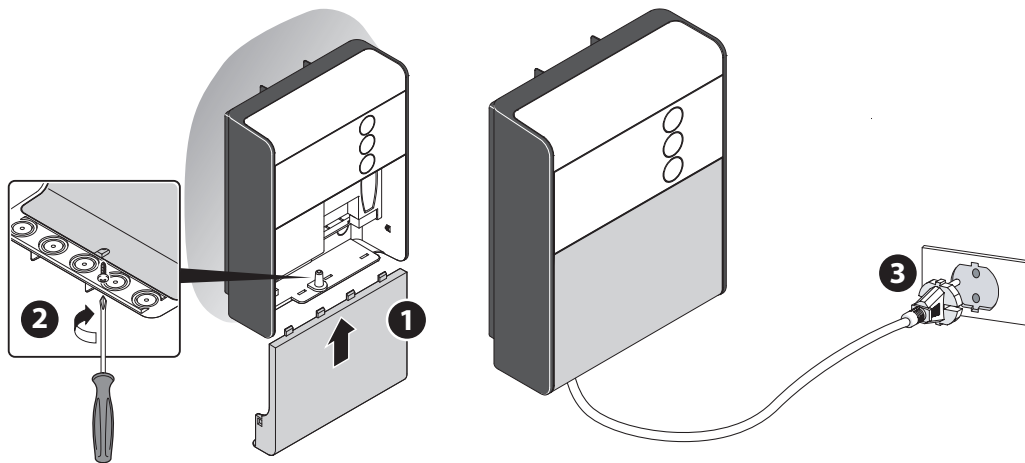

To install the specified accessories, refer to the respective instruction manuals.

4 TESTING AND COMMISSIONING

These are the most important phases of automation set-up to ensure maximum system safety.

This must be performed by qualified and experienced personnel who must take charge of establishing the tests necessary to verify the solutions adopted in respect of risks and verify the compliance of the system with applicable standards, legislation and regulations, in particular all requirements of the standard 12445 which establishes the test methods for checking automations for doors and gates.

Any supplementary equipment must be tested separately for operation and interaction with the SPY: refer to the respective user manuals.

4.1 - Testing

The testing procedure can also be performed as a periodic check of the automation devices.

Each component of the system (sensitive edges, photocells, emergency stop, etc.) requires a specific testing phase. To do so, follow the procedures given in the instruction manuals.

Run the setup of the control unit.

Run the SPY testing as follows:

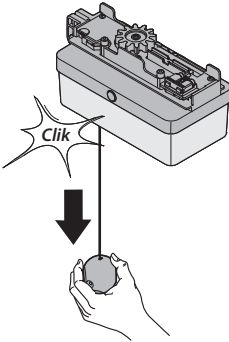
01.	Ensure that all specifications in the "WARNINGS" chapter have been observed in full.
02.	<p>Release the garage door by pulling the release cord downwards and see if you can manually move the garage door in opening and closing with a force:</p> <ul style="list-style-type: none"> - private use = 150 N maximum - industrial/business use = 260 N maximum
	
03.	Put the motor carriage back.
04.	Using the key switch or radio transmitter or the control unit buttons, test the opening and closing of the garage door and make sure that it moves in the intended direction.
05.	The test should be carried out a number of times to make sure that the garage door moves smoothly, that there are no points of excessive friction and that there are no defects in the assembly or adjustments.
06.	Verify the correct operation of all safety devices in the system (photocells, sensitive edges etc.): in particular, when a device is activated, the BlueBUS/OK LED on the control unit flashes 2 times quickly, confirming that the control unit recognises the event.
07.	<p>Check the operation of the photocells and any interference with other equipment:</p> <ol style="list-style-type: none"> 1 - pass a dia. 5 cm length 30 cm cylinder along the optical axis, first close to the TX, then close to the RX 2 - check that the photocells trip in any condition, switching from active to alarm and back 3 - check that tripping the photocell results in the intended response of the control unit: e.g., when tripped during a closing stroke, the gate changes direction.
08.	<p>If the dangerous situations caused by the movement of the garage door have been safeguarded by limiting the impact force, the user must measure the impact force according to the EN 12445 standard.</p> <p>If the adjustment of the 'Speed' and control of the 'Motor Force' are used to assist the system for the reduction of the impact force, try to find the adjustment that gives the best results.</p>

4.2 - Commissioning

Commissioning can take place only after all testing phases have been terminated successfully (par. 4.1).

Partial or "makeshift" commissioning is strictly prohibited.

01.	Prepare and store the technical documentation for the automation for at least 10 years. This must include at least: an assembly drawing of the automation, a wiring diagram, an analysis of hazards and solutions adopted, a manufacturer's declaration of conformity of all the devices installed (for SPY use the annexed CE declaration of conformity); a copy of the automation system instruction manual and maintenance schedule.
02.	Post a permanent label or sign near the door detailing the release and manual manoeuvre operations (refer to the figures in "Instructions and warnings for users of the SPY gearmotor").
03.	<p>Post a permanent label or sign near the gate containing this picture (min. height 60 mm):</p>
	
04.	Using the key switch or radio transmitter or the control unit buttons, test the opening and closing of the garage door and make sure that it moves in the intended direction.
05.	Post a label on the garage door providing at least the following data: type of automation, name and address of manufacturer (person responsible for the "commissioning"), serial number, year of manufacture and 'CE' mark.

06.	Prepare the declaration of conformity of the automation system and deliver it to the owner.
07.	Give the owner the user manual (tear-out insert).
08.	Prepare and give the owner the maintenance schedule.
09.	The force adjustment is an important safety aspect and must be done with care by an expert technician. Important! - Adjustments set to force loads higher than those allowed may cause injury to persons and animals or damage to things. Adjust the force to the minimum available value to allow rapid and reliable detection of any obstacles.
10.	Before commissioning the gate, inform the owner in writing about the attendant residual risks.

5 PROGRAMMING

In this manual the programming procedures are explained with the use of icons and their meanings are given in the following glossary:

Symbol	Description	Symbol	Description
	LED ON		release the buttons
	LED OFF		on the control unit, select the OPEN button
	fast flashing LED		on the control unit, select the STOP button (SET)
	very fast flashing LED		on the control unit, select the CLOSE button
	LED flashing LONG		on the control unit, select the OPEN + CLOSE buttons
	LED flashing SHORT		on the control unit, select the OPEN + STOP buttons (SET)
	indicates the transition between states		on the control unit, select the STOP (SET) + CLOSE buttons
	shut off mains power		PROG selector = default location
	supply mains power		move the PROG selector to the left = position 1
	wait		move the PROG selector to the right = position 0
	observe / check		select LEDs/functions
	within a few seconds		device acquisition phase
	press and release the button		position acquisition phase
	press and release the buttons at the same time		radio transmitter acquisition phase (Mode 2: Step-by-Step command)
	press and release a transmitter button		move the garage door to the halfway position

	hold down a transmitter button		release and lock the gearmotor
	release the transmitter key		closing-opening-closing
	press and hold the buttons		end of procedure

5.1 - Control unit quick set-up

The 'Control unit quick set-up' function allows for speeding up the motor's commissioning. **It only works with virgin memory.** After the initial flashing of the LEDs, the control unit waits for the acquisition of the devices by making L1 + L2 flash slowly. Control unit quick set-up only starts with the PROG selector to the right ()

If you use a category B resistive sensitive edge (according to EN13849-1, -2) to limit the impact force (according to CAT 2 and Performance Level C), you must activate parameter L5 (level one programming) and then perform the device search procedure.

Memorisation procedure

01.	02.		03.

04.	05.	06.	07.









⚠ CAUTION! - If, in the next step, the first manoeuvre to be carried out is an Opening manoeuvre, interrupt the position acquisition and invert – on the control unit – the electrical connections on the motor terminal. Repeat the procedure from point 1.	08.	

09.		10.
		11.

11.	

5.2 - Standard Setup

The control unit contains one selector and 3 buttons: these behave differently depending on the status of the programming selector.

Functions with PROG selector (mod. SPYBOX - SPYBOX B - SPYBOX B HS - SPYBOX B/V1)			
 OPERATION DURING PROGRAMMING Note: LEDs L1...L8 indicate the status of the active functions ON: function active OFF: function NOT active FLASHING: procedure under way (e.g. L1+L2 = device acquisition under way)		 NORMAL OPERATION Note: the LEDs L1 ... L8 remain off	
key	function	key	function
OPEN 	shifts the programming point to the left	OPEN 	commands and opening manoeuvre
STOP 	- accesses the programming phase - modifies the parameter	STOP 	- stops the current manoeuvre - with the motor stationary, it inverts the status of the courtesy light
CLOSE 	shifts the programming point to the right	CLOSE 	commands a closing manoeuvre

⚠ CAUTION! - With the selector set to the left (in programming mode, therefore), no movement command can be imparted to the motor. To move the motor, shift the selector back to the right (Normal Operation mode).



5.3 - Device Acquisition

After connecting the power supply, if you have not run the Quick Setup (section 5.1), it is necessary to carry out the acquisition of the devices connected to the STOP input (indicated by the flashing of the LEDs L1 and L2).

If you use a category B resistive sensitive edge (according to EN13849-1, -2) to limit the impact force (according to CAT 2 and Performance Level C), you must activate parameter L5 (level one programming) and then perform the device search procedure.

⚠ CAUTION! - During this procedure, the control unit switches the internal relays to run a few functional tests.

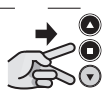
⚠ CAUTION! - The device acquisition phase must be performed even if there is no device connected.



01.	02.	03.
	 (OPEN + STOP) 3 s = L1 + L2 	 The acquisition memorises the status of the ALT input

5.4 - Acquisition of Opening and Closing Positions





After acquiring the devices (section 6.2) it is necessary to enable the control unit to recognize the opening and closing positions of the garage door.

In this phase, the length of the stroke of the garage door is measured, from the closing mechanical stop to the opening mechanical stop.







⚠ CAUTION! - If the first manoeuvre to be carried out is an Opening manoeuvre, interrupt the procedure and invert – on the control unit – the electrical connections on the motor terminal. Repeat the procedure from point 1.

01.	02.	03.	04.
	 (STOP + CLOSE) 3 s = L3 + L4 	Start manoeuvres: close, open and close. During this sequence the positions are memorised	





5.5 - Deletion of parameters memory

01.	02.	03.	04.
	 (OPEN + CLOSE) 3 s	L1  =  (OPEN + CLOSE)	Start deleting all memory except radio codes (section 6.5) 

5.6 - Deletion of radio codes memory

01.	02.	03.	04.
	 (OPEN + CLOSE) 6 s	L2  →  =  (OPEN+CLOSE)	Start deleting all the radio codes in the memory 

5.7 - Deletion of total memory

01.	02.	03.	04.
	 (OPEN+CLOSE) 10 s	L3  =  (OPEN+CLOSE)	Start deleting all memory, including radio codes 

5.8 - Parameter programming (ON-OFF)









⚠ IMPORTANT! - The parameter modification procedures must be completed within maximum 10 seconds from the start of the execution: you must therefore first read the legend contained in the following paragraphs and then proceed.



During normal operation, in other words when the control unit **is not in 'parameter programming' mode**, LEDs 'L1 ... L8' are always switched off. When the user enters the programming mode, LEDs 'L1 ... L8' indicate **the status of the respective function; for example, 'L1' is lit when the 'Automatic Closing' function is enabled.**

5.8.1 - 1st level Parameters

Table 4 – 1st level Parameters		
LED	Function	Description
L1	Automatic Closing	Run the automatic closing of the garage door when it is open, after the programmed pause time has elapsed
L2	Close After Photo	Run the closing of the garage door only after transit has been completed. Caution! - You need to have performed the installation of the photocells
L3	Always Close	After switching on the control unit, a closing manoeuvre starts preceded by 3 sec. of pre-flashing
L4	Stand by	This function reduces power consumption: after 1 minute from the end of the manoeuvre, the control unit turns off the output and the BlueBUS photocell transmitters. For use with the Solemyo system you must enable the "Stand by - all" mode using the Oview programmer
L5	STOP 8K2	Run a test of the 8K2 sensitive edge at the start of each manoeuvre. Activate the function then acquire the devices with the 8K2 edge connected.
L6	Lock OPEN and CLOSE buttons	Deactivates the operation of the OPEN and CLOSE buttons on the lid of the box, when the switch is in 0 position
L7	Lock transmitter memorisation	Prevents the memorisation of new transmitters on the internal radio receiver
L8	Deactivates internal radio receiver	Deactivates the operation of the internal radio receiver: you will not be able to command the control unit via the transmitters memorised in the internal radio receiver

Programming procedure 1st level

01.	02.	03.	04.	05.
	 (SET) 3 s	L1  =  (SET)	 to select the desired function (LED: L1 ... L8) use the OPEN or CLOSE button	 (SET) to change the status of the function
				 = OFF  = ON

06.
 10 s = exit from progr. or 

5.8.2 - Level 2 parameters (ADJUSTABLE PARAMETERS)

Table 5 – 2nd level Parameters			
Input LED	Parameter	Level	Value
Note: the parameters with a grey background are factory settings			
L1	Pause Time	L1	10s
		L2	20s
		L3	40s
		L4	60s
		L5	80s
		L6	120s
		L7	160s
		L8	200s

L2	Operating modes	L1	SbS: open - stop - close - stop	
		L2	SbS: open - stop - close - stop	
		L3	SbS: open - close - open - close	
		L4	Apartment block	
		L5	Hold-to-run	
		L6	Industrial mode	
		L7	-	
		L8	-	
L3	Motor speed	L1	Speed 1 - 30% low	
		L2	Speed 2 - 50%	
		L3	Speed 3 - 75%	
		L4	Speed 4 - 100% high	
		L5	Open V3 - Close V1	
		L6	Open V3 - Close V2	
		L7	Open V4 - Close V2	
		L8	Open V4 - Close V3	
L4	Flash output	L1	Garage door open indicator	
		L2	Active if garage door closed	
		L3	Active if garage door open	
		L4	Flashing light (12V)	
		L5	Flashing light (24V)	
		L6	Electric block	
		L7	Suction cup	
		L8	Radio channel 2	
L5	Motor force Lev 0% = low Lev 100% = high	L1	OP lev 25%	CL lev 25%
		L2	OP lev 50%	CL lev 50%
		L3	OP lev 75%	CL lev 75%
		L4	OP lev 100%	CL lev 100%
		L5	OP lev 75%	CL lev 25%
		L6	OP lev 75%	CL lev 50%
		L7	OP lev 100%	CL lev 50%
		L8	OP lev 100%	CL lev 75%
L6	Motor sensitivity low = more force high = little force	L1	Disabled	
		L2	OP lev 60%	CL lev 60%
		L3	OP lev 60%	CL lev 70%
		L4	OP lev 60%	CL lev 80%
		L5	OP lev 60%	CL lev 90%
		L6	OP lev 70%	CL lev 70%
		L7	OP lev 70%	CL lev 80%
		L8	OP lev 70%	CL lev 90%
L7	INP2	L1	SbS (NO)	
		L2	Open (NO) (SPYBOX B)	
		L3	Closes (NO)	
		L4	Partial open 1 (NO)	
		L5	STOP (NC)	
		L6	Photo (works in closing – NC) (SPYBOX)	
		L7	Photo1 (works on opening and closing – NC)	
		L8	Photo2 (works on opening – NC)	













Warning!: For 'Radio management' (LED L8) after selecting the Level (L1 ... L8):



⚠ in this phase there are 10 s available for each transmitter to be memorised

L8	Radio management	L1	Memorise code in mode 1
		L2	Memorise code in mode 2 - cmd SbS
		L3	Memorise code in mode 2 - cmd OP PART
		L4	Memorise code in mode 2 - cmd OP
		L5	Memorise code in mode 2 - cmd CL
		L6	Memorise code in mode 2 - cmd STOP
		L7	Memorise code in mode 2 - cmd Courtesy light
		L8	Delete single code

Programming procedure 2nd level

01.	02.	03.	04.	05.
	 (SET) 3 s	L1  =  (SET)	 to select the desired function (LED: L1 ... L8) use the OPEN or CLOSE button	 (SET) until completion of steps 06 and 07
06.	07.	08.	09.	
 3 s =  (led L1...L8)	 to select the desired function (LED: L1 ... L8) use the OPEN or CLOSE button	 (SET)	 10 s = exit from progr. or 	

5.9 - Integraradio receiver

For remote control the control unit incorporates a radio receiver with 433.92 MHz frequency and FLOR coding. Each radio transmitter is recognised by the radio receiver by means of a 'code' which is different from every other transmitter: you must run the memorisation of the transmitters to prepare the receiver to recognise each single transmitter.

There are two types of memorisation: Mode 1 and Mode 2.

• **Mode 1 (see L8 - Table 5):**
automatically assigns the commands indicated in table 6 to the transmitter's keys.

Each transmitter is memorised in a single step, with all keys programmed: it does not matter which key is pressed. (One memory section is occupied for each memorised transmitter). N.B.: when memorised in Mode 1, a transmitter can control only one automation.

Transmitter key	Command
1	SbS
2	Partial open
3	Open
4	Close

• **Mode 2 (see L8 - Table 5):**
freely assigns a command among those listed in table 7.

LED Input	Parameter	Level	Value
L8	Radio management	L1	Memorise code in mode 1
		L2	Memorise code in mode 2 – cmd SbS
		L3	Memorise code in mode 2 – cmd OP PART
		L4	Memorise code in mode 2 – cmd OP
		L5	Memorise code in mode 2 – cmd CL
		L6	Memorise code in mode 2 – cmd STOP
		L7	Memorise code in mode 2 – cmd Courtesy light

For each phase, only one key is memorised (the one pressed during memorisation). (One memory section is occupied for each key).

⚠ IMPORTANT! - The memorisation procedures can be executed within 10 seconds maximum: you need to read the instructions of sections (5.10, etc) below and then proceed.

5.10 - Radio diagnostics during memorisation or deletion of radio transmitters







During the memorisation or deletion of the transmitters, the green LED flashes quickly. The red programming LEDs can perform the following forms of flashing:

Memorisation	Deletion
1 slow flashes: transmitter already memorised	1 slow flash: code not found in memory
3 slow flashes: transmitter memorised successfully	5 quick flashes: code deleted
8 slow flashes: memory full	
2 quick flashes: memory locked	

5.11 - Remote memorisation











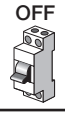

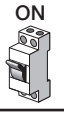

It is possible to memorise a new transmitter without having to access programming. You must have a previously memorised transmitter (old). The new transmitter will be memorised with the same characteristics as the old one.

The procedure is as follows: **with the motor stopped, stand close to the control unit**

01.	02.	03.
NEW transmitter	OLD transmitter already memorised	NEW transmitter
 8 s 	 2 s  2 s  2 s	 5 s
CAUTION! - If you start a manoeuvre you must repeat the procedure from point 01		
If the procedure has been successful the new transmitter is memorised (a manoeuvre may start).		

5.12 - Radio quick set-up

To speed up the memorisation of a new radio command, a rapid procedure is available that allows for associating a single button as an SbS command in mode 2. This procedure can only be used at the start-up.

01.	02.	03.	04.	05.	06.
	OFF 	 (SET)	ON 	 (SET) 3 s	L1  =  (SET)
07.   ÷ 5 s 		08.   ÷ 5 s 			
		08.  10 s		09.  = 	

5.13 - External radio receiver (SPYBOX B only)

The SPYBOX B control unit has an available connector that lets you use an optional radio receiver (SMXI, SMXIS, OXI).

5.13.1 - Memorisation of radio transmitters

• Using a receiver:

with the memorisation of the transmitter in Mode 1 (see receiver manual) the transmitter buttons are associated with the commands on the control unit as follows:

Key	Command
N° 1	Step-by-step
N° 2	Partial open
N° 3	Open
N° 4	Close

• Using an OXI receiver:

with the memorisation of the transmitter in Mode 2 (see receiver manual), each button on the transmitter can be associated with one of the following commands on the control unit:

Key	Command
N° 1	Step-by-step
N° 2	Partial open 1
N° 3	Open
N° 4	Close
N° 5	Stop
N° 6	Step-by-Step Condominium
N° 7	Step-by-Step High priority
N° 8	Release and Open
N° 9	Release and Close
N° 10	Open and Lock automation
N° 11	Close and Lock automation
N° 12	Lock automation
N° 13	Release automation
N° 14	Timer On Courtesy light
N° 15	On-Off Courtesy Light

6.1 - Connecting an Oview

You can connect the Oview programming unit to the control unit, via the IBT4N interface through a bus cable with 4 electricity wires inside.

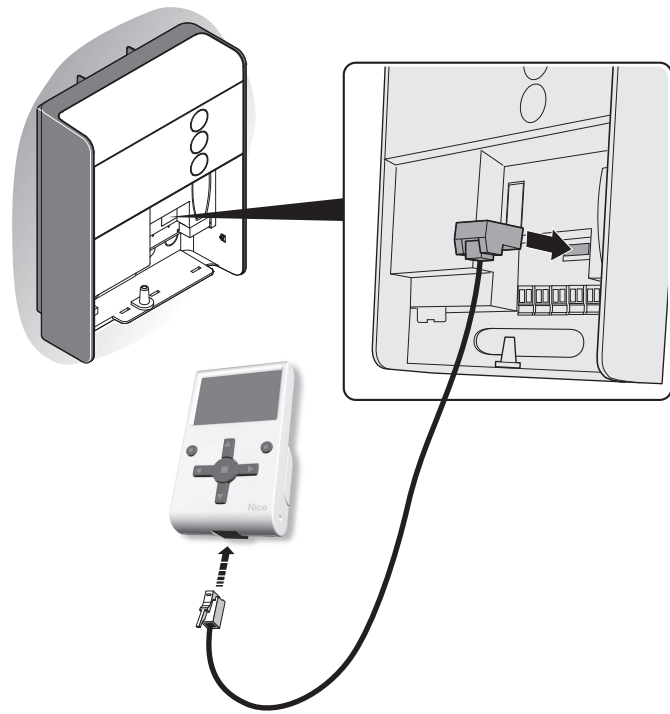

This unit enables quick and complete programming of the functions, adjustment of the parameters, firmware updates, diagnostics to detect malfunctions and periodic maintenance.

The Oview can be used at up to 100 m away from the control unit.

If several control units are networked with each other in a BusT4 network, by connecting the Oview to one of them, you can view on the display all the networked control units (up to a maximum of 16 units).

The Oview unit can also be left connected to the control unit during normal operation of the automation, so that the user can send commands using a specific menu.

Furthermore, if the control unit has an OXI type radio receiver, the Oview allows you to access the parameters memorised on this receiver.

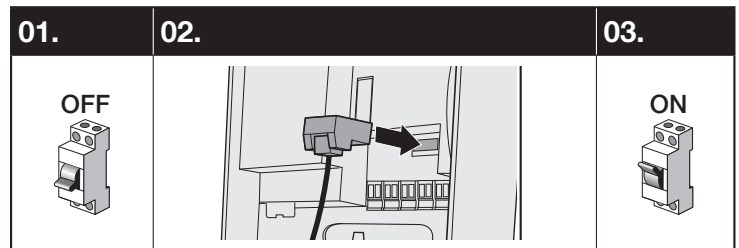

Further information is available in the Oview unit instruction manual and in the “SPY - Programmable functions using the Oview programmer”, also available on www.niceforyou.com.

6.2 - Adding or removing BlueBUS devices (SPYBOX B and SPYBOX B HS only)

In the SPYBOX B control unit you can at any time add new devices connected to the BlueBus and Stop or delete others that are already present: see section 5.3.

Bluebus Input

The BlueBus system allows you to connect compatible devices using only two wires which carry both the power supply and the communication signals.

All devices are connected in parallel on the same 2 Bluebus wires and there is no need to observe any polarity. Each device is recognized individually because during installation a unique address is assigned to it.

You can connect photocells, safety devices, control devices, such as keyboards and transponder card readers, signal lights, etc. to the Bluebus system. During the device acquisition phase, the control unit recognises them individually and can detect with extreme safety any anomalies.

⚠ When a device connected to the Bluebus is added or removed, you need to perform the device acquisition phase (section 5.3).

Photocells

The Bluebus system allows the control unit to recognise the photocells, by adjusting the addressing of the jumpers (Table 9) and allows you to assign the correct value of the ‘obstacle detection’ function.

The addressing operation must be performed both on the TX and RX by setting the jumpers in the same way and making sure there are no other pairs of photocells with the same address. Photocells can be installed as shown in the figures below.

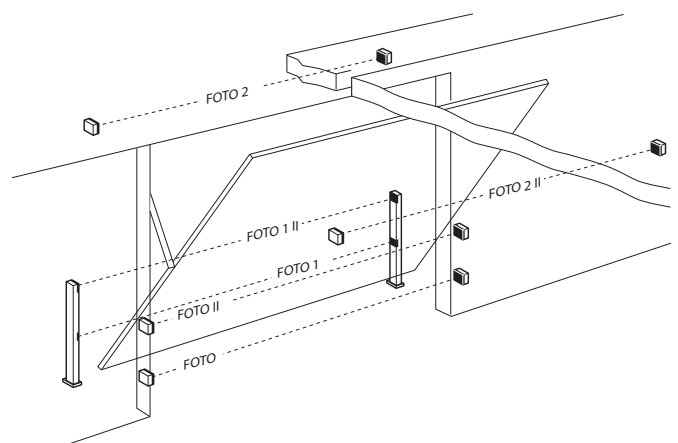
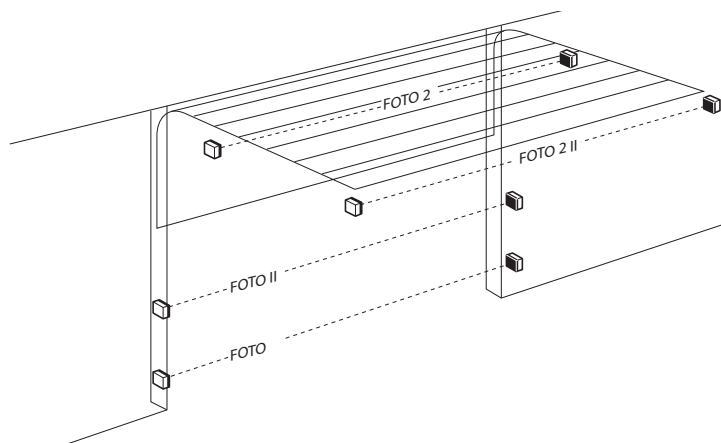











Table 9

Photocells	Jumper	
PHOTO	Photocell h = 50 activation during closing (reverses to 'open')	
PHOTO II	Photocell h = 100 activation during closing (reverses to 'open')	
PHOTO 1	Photocell h = 50 activation during closing (temporary stop and reverses to 'open')	
PHOTO 1 II	Photocell h = 100 activation during closing (temporary stop and reverses to 'open')	
PHOTO 2	Photocell with activation during opening (stops the manoeuvre)	
PHOTO 2 II	Photocell with activation during opening (stops the manoeuvre)	
PHOTO 3	Single photocell with activation during opening and closing (temporary stop and reverses in 'open')	
FA1	Photocell for opening command (cut jumper A on the back of the TX and RX cards)	
FA2	Photocell for opening command (cut jumper A on the back of the TX and RX cards)	

⚠ IMPORTANT! - After the installation or removal of photocells, you need to perform the device acquisition phase (section 5.3)

Note: you can connect 2 photocells to the Bluebus input, with the 'FA1 open' and 'FA2 open' command function (it is necessary to cut the jumper A on the back of the TX and RX cards). When these photocells intervene, the control unit commands an opening manoeuvre. For further information, refer to the instruction manual for the photocells.

6.3 - STOP input connection

The Stop input causes the immediate stoppage of the manoeuvre, followed by a brief inversion. Devices with contact types Normally Open (NO), Normally Closed (NC) or devices with a constant resistance of 8.2 KΩ (such as sensitive edges) can be connected to this input. During the device acquisition phase, the control unit recognises the type of device connected to the Stop input and later, during normal use of the automation, the control unit commands a Stop when it senses a change with respect to the acquired situation.

⚠ CAUTION! - If you want to ensure category 3 safety with faults according to EN 954-1, you must only use the devices with 8.2 KΩ constant resistance output.

If the connection with 8.2 KΩ constant resistance is used, you can program a device test, at the start of each manoeuvre. **To activate the 8K2 test mode, you must enable the L5 parameter in the 1st level menu.**

6.4 - Power for external devices

If you want to power external devices (proximity reader for transponder cards or the backlight of a key selector) you can connect the device to the product control unit as shown in the figure at the side. The power supply voltage is 30V DC +5% to -20% with a maximum available current of 100 mA.

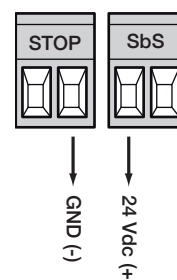

6.5 - Spylight

The Spylight module is the new light model that can be used as a courtesy light by installing it directly in the SPYRAIL rails. A maximum of 2 Spylights can be installed on the same rail, while being very careful when positioning the modules: **each individual Spylight MUST be positioned outside of the carriage's useful stroke, in other words, beyond the stop limit switch.**

The SPYLIGHT is designed to remain lit during the entire duration of the manoeuvre: when this terminates, the light will remain lit for a time equal to the value set in the 'Courtesy Light Time' parameter (default value: 60 seconds). With the motor stationary, the Courtesy Light can be switched on or off by pressing the STOP button or through the Oview programmer: for each command received, the status of the light will be inverted. The maximum time available for the illumination of the Courtesy Light is 4 minutes, after which the light will switch off automatically.

⚠ IMPORTANT! - Whenever a SPYLIGHT is added or removed, it is compulsory to run the device acquisition procedure (Paragraph 5.3):
- It is highly inadvisable to impart movement commands without first having run this procedure.
- The SPYLIGHT re-proposes all the anomaly signals represented in the control unit through the internal courtesy light and the BlueBus LED. At the end of the representation, the SPYLIGHT lights will switch off automatically.

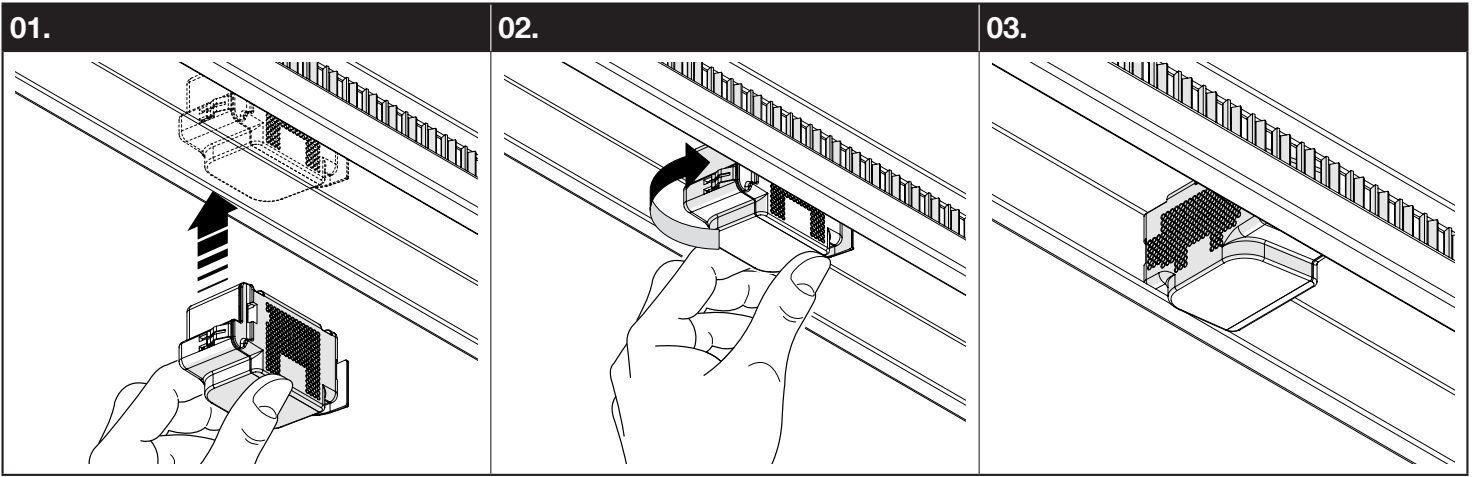

6.6 - Back-up battery model PS324 (only for SPYBOX B and SPYBOXB HS)

In the event of mains power failure, SPYBOX B is designed to be powered by model PS324 backup battery. To perform the installation and connection of the battery, proceed as follows:

⚠ CAUTION! - The backup battery should only be connected to the control unit after completing all phases of installation and programming, because the battery is an emergency power supply.

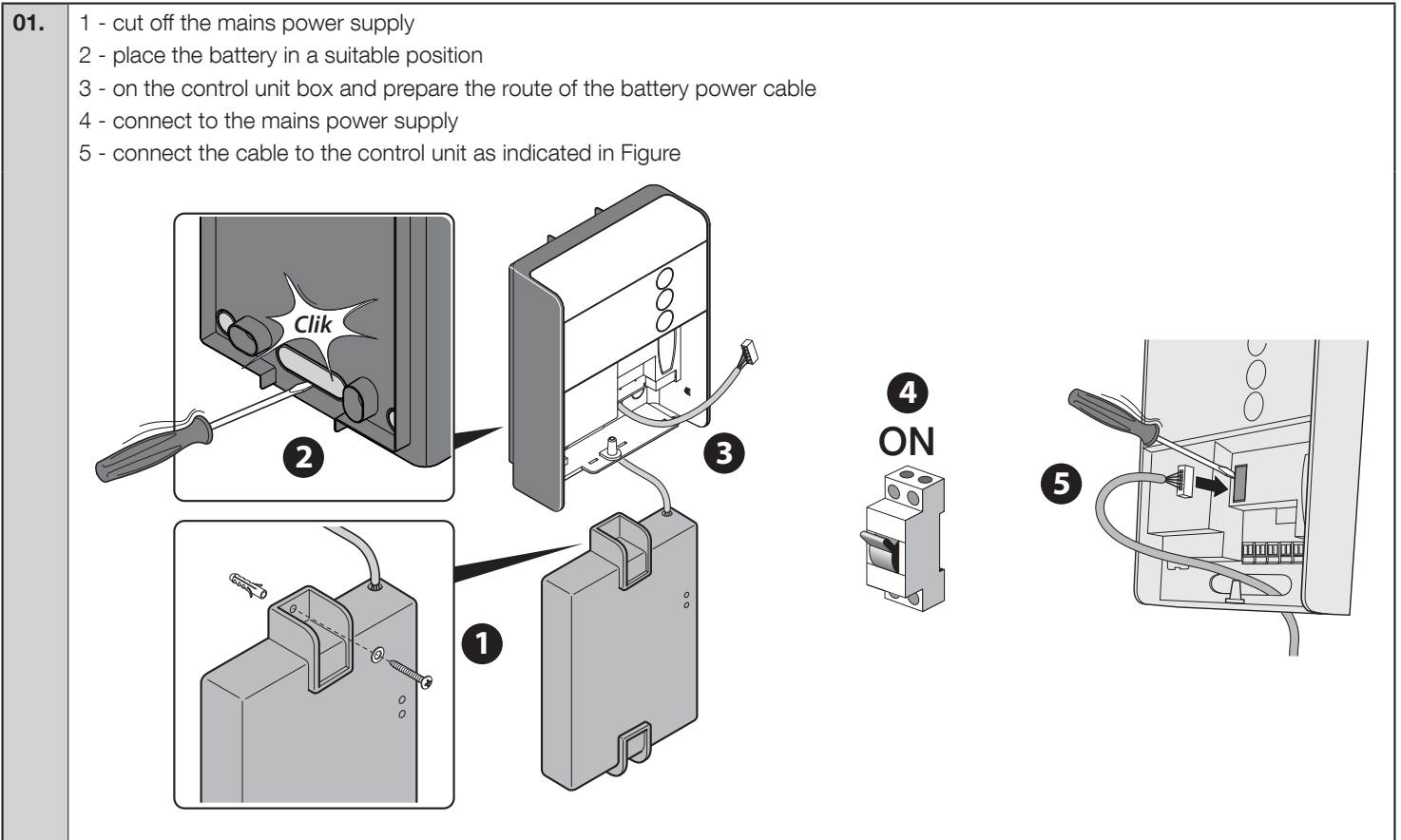

6.7 - Solemyo System (only for SPYBOX B)

SPYBOX B is designed to be powered with the 'Solemyo' photovoltaic power system. For connection to the control unit, you must use the socket of the backup battery.

⚠ IMPORTANT! - When SPYBOX B is powered by the "Solemyo" system IT MUST NOT BE POWERED from the electricity mains at the same time.

SPY will perform a maximum number of operations per day depending on the amount of solar energy available at the installation location and the time of year.

Note – Before installing, it is important to check in the Solemyo instruction manual whether the maximum number of possible manoeuvres is compatible with its intended use.

Warning – In order to have effective performance from 'Solemyo' the 'Stand-by - All' function on the control unit needs to be ON: this function can only be activated using the Oview programmer.

6.8 - Safety device for pedestrian door

The electrical board on the motor has a terminal for connecting a safety device for the pedestrian gate (microswitch Normally Closed - NC) that stops the motor if the pedestrian door remains open.

IMPORTANT! - Only use contacts with tripping current of at least 10 A.

The connecting cable must be:

Length = 3 m maximum

Section = 1 mm² minimum (diameter of cable route hole on the motor carriage is 6.5 mm)

For the connection, follow the instructions below.

- 01.**
- a - connect the safety device (refer to your instruction manual)
 - b - remove the cover of the motor carriage
 - c - remove the protective sheath of the hole on the motor carriage used for passing the cable
 - d - pull the cable through the hole and position it near the edge of the carriage up to the terminal (1-2)
 - e - remove the jumper on the terminal
 - f - connect the two wires to the terminal

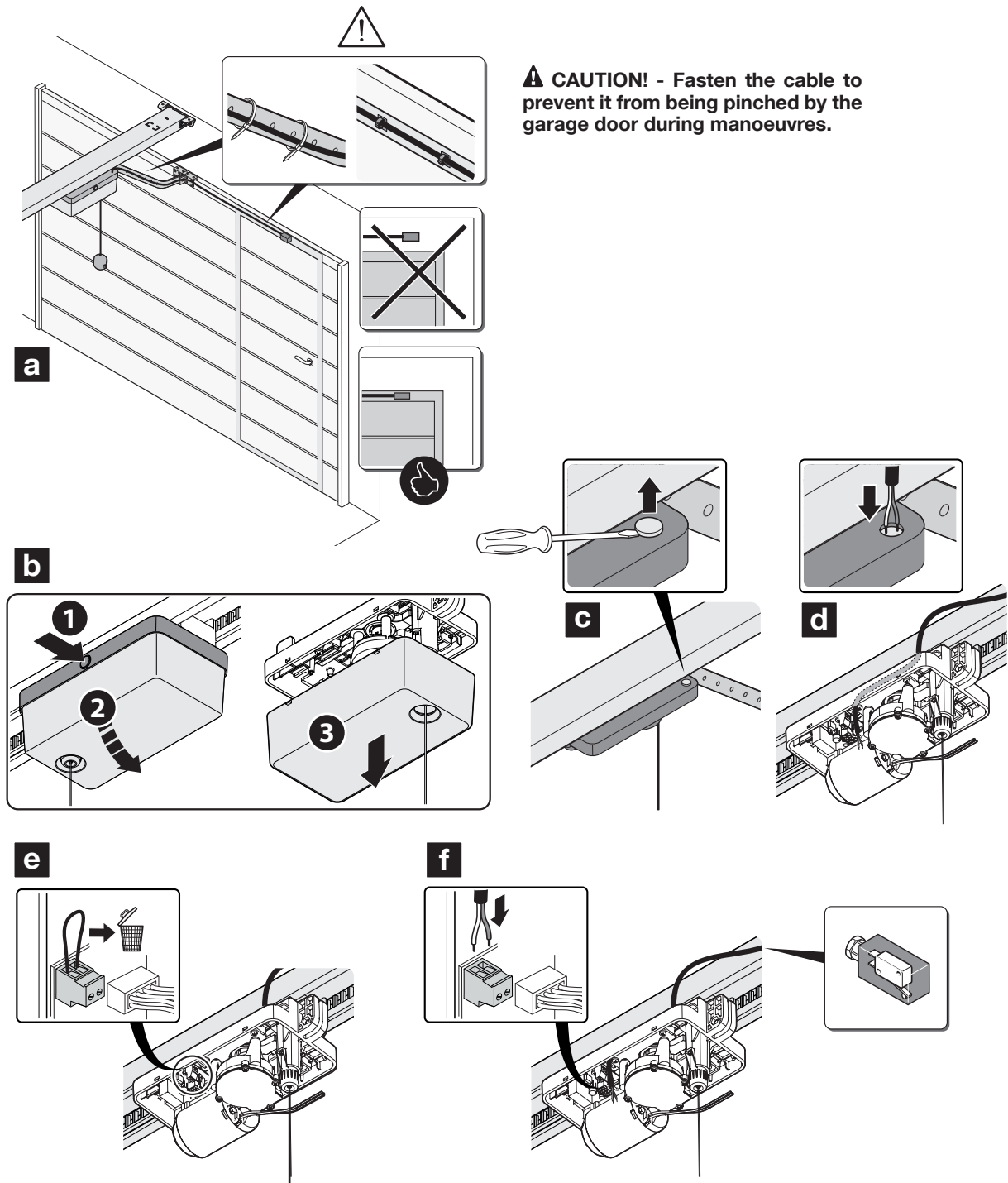

6.9 - "Move anyway" function

If one or more safety devices do not work properly or they are out of order, this feature allows you to control the motor in the 'Hold-to-run' mode all the same (for details see the chapter 'User Manual').

6.10 - Diagnostics

Some devices are display messages to identify their status and faults.

6.10.1 - Control unit signals

The green and red LEDs on the control unit produce special signals to report normal operation and any anomalies.

Table 10 lists the signals:

Table 10		
LED OK /BB	Cause	Solution
Off	Fault	<ul style="list-style-type: none"> - Check for presence of power supply; check that the fuses are not blown: in this case, identify the cause of the fault and then replace them with versions with the same specifications. - Check for short-circuited cables. - Check whether the control unit thermal cutout has tripped and switched it off. Wait for 1 minute and check whether it starts up again.
On for more than 20 seconds.	Fault	A serious malfunction has occurred; try switching off the control unit for 20-30 seconds; if the condition persists, it means there is a malfunction and the circuit board must be replaced.
Flashing light	Ok	Normal control unit operation.
Double flash	The status of the inputs has changed	This is normal when there is a change in one of the inputs: SbS, STOP, OPEN, CLOSE, triggering of photocells, or the radio transmitter is in use or the PROG switch is on.
Series of flashes with pause	Diagnostics	It corresponds to the flashing light or the courtesy signal (see Table 9).

Description of Programming LEDs with PROG selector positioned on the left

L1 LED	Description
Off	During normal operation the device indicates 'Automatic Closing' is not active.
On	During normal operation the device indicates 'Automatic Closing' is active.
Slow flashing	<ul style="list-style-type: none"> • Function programming in progress. • If it flashes together with L2, it means that the user must carry out the device acquisition phase (see section 5.3).
L2 LED	Description
Off	During normal operation the device indicates 'Close after photo' is not active.
On	During normal operation the device indicates 'Close after photo' is active.
Slow flashing	<ul style="list-style-type: none"> • Function programming in progress. • If it flashes together with L1, it means that the user must carry out the device acquisition phase (see section 5.3).
L3 LED	Description
Off	During normal operation the device indicates 'Always close' is not active.
On	During normal operation the device indicates 'Always close' is active.
Slow flashing	<ul style="list-style-type: none"> • Function programming in progress. • If it flashes together with LED L4, the user must run the learning phase of the opening and closing positions (section 5.4).
LED L4	Description
Off	During normal operation, the device indicates 'Standby' is not active.
On	During normal operation, the device indicates 'Standby' is active.
Slow flashing	<ul style="list-style-type: none"> • Function programming in progress. • If it flashes together with LED L3, the user must run the learning phase of the Opening and Closing positions (section 5.4).
LED L5	Description
Off	During normal operation the device indicates 'Test STOP 8K2' is not active.
On	During normal operation the device indicates 'Test STOP 8K2' is active.
Slow flashing	Function programming in progress.
LED L6	Description
Off	During normal operation the device indicates 'Lock command buttons' is not active.
On	During normal operation the device indicates 'Lock command buttons' is active.
Slow flashing	Function programming in progress.
LED L7	Description
Off	During normal operation the device indicates 'Lock transmitter memorisation' is not active.
On	During normal operation the device indicates 'Lock transmitter memorisation' is active.
Slow flashing	Function programming in progress.

LED L8	Description
Off	During normal operation the device indicates 'Internal radio receiver' is activated.
On	During normal operation the device indicates 'Internal radio receiver' is deactivated.
Slow flashing	Function programming in progress.

6.10.2 - Signals for warning light, courtesy light or SPYLIGHT

If a flashing light is connected to the FLASH output on the control unit, this will flash once every 1 second while the manoeuvre is being performed.

If any anomalies occur, the warning light will emit shorter flashes that are repeated twice with a 1-second pause in between. The same signals are emitted also by the LED courtesy light and by the OK/BB LED and the SPYLIGHT accessory.

Table 11 lists the various signals:

Table 11		
Signal	Cause	Solution
1 flash 1 sec pause. 1 flash	Bluebus system error	The check on which devices are connected to the BlueBus, performed at the start of the manoeuvre, does not reveal the same devices memorised during the device acquisition phase. Some faulty devices may be present: check and replace them as necessary. If any changes have been made, you must rerun the device acquisition phase (section 6.2). Not available in the SPYBOX version
2 flashes 1 sec pause. 2 flashes	Triggering of a photocell	At the starting of the manoeuvre, one or more photocells do not enable it; check to see if there are any obstacles.
3 flashes pause of 1 sec 3 flashes	Activation of the 'Motor Force' limiting device	While moving, the garage door experienced excessive friction; check the cause. If necessary, increase the value of the 'Motor Force' or reduce the 'Obstacle detection sensitivity' value
4 flashes pause of 1 sec 4 flashes	Activation of the STOP input	At the start of or during the manoeuvre, the STOP input was activated; identify the cause. You have enabled the 'Test STOP 8K2' but the edge connected to the STOP input is not of the 8K2 resistive type.
5 flashes pause of 1 sec 5 flashes	Error in the internal parameters of the electronic control unit	Remove and then connect the mains power. If the error persists, run the 'Deletion of total memory' (section 5.7) and redo the installation. If the condition persists, there may be a serious fault and you need to replace the electronic board.
6 flashes pause of 1 sec 6 flashes	Not used	
7 flashes pause of 1 sec 7 flashes	There is an error in the internal electric circuits	Disconnect the mains power supply to the control unit for 20-30 sec, then switch on again and try to send the command again. If the condition persists, there may be a serious fault on the board and you will need to replace it.
8 flashes pause of 1 sec 8 flashes	A command that does not permit other commands to be performed is already present.	Check the type of command that is always present; for example, it may be a command from a clock on the "Step-by-Step" input.
9 flashes pause of 1 sec 9 flashes	Lock automation	Send the 'Release Automation' command or command the manoeuvre with 'Step-by-Step High Priority'.
10 flashes pause of 1 sec 10 flashes	During the position learning phase, there is no absorption by the motor	Verify that the connections between the cap with cable, the guide and the motor carriage are working. Make sure that the motor cable is connected to the control unit.
Rapid flashing of the courtesy light for 10 sec.	Short circuit or over-absorption on motor output	Check that there are no short-circuits between the motor cables or between the guide and the strip. Check that the garage door is properly balanced.

7 WHAT TO DO IF...

In case of malfunction due to problems during installation or failure of parts, refer to table 12:

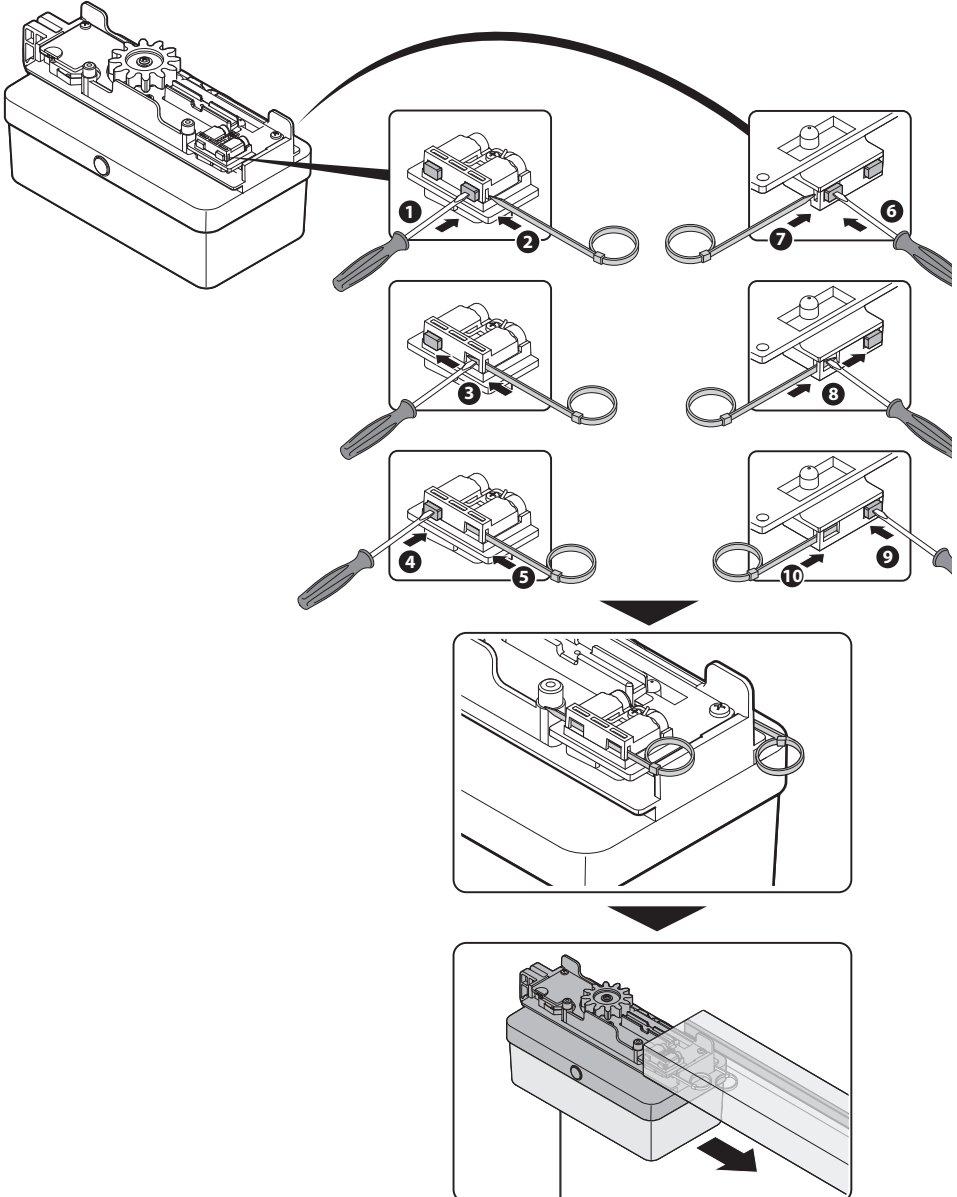
Table 12	
Problem	Solution
The radio transmitter does not control the gate and the led on the transmitter does not light up	Check to see if the transmitter batteries are exhausted, if necessary replace them.
The radio transmitter does not control the gate but the led on the transmitter lights up	Check to see if the transmitter has been memorised correctly in the radio receiver. Check that the emission of the transmitter radio signal is correct by means of this empirical test: push a key and rest the LED on the aerial of a normal radio (ideally an economical one) that is switched on and tuned in, as close as possible, to 108.5 Mhz FM; a slight crackling sound should be heard
No manoeuvre starts and the OK LED fails to flash.	Check that the product is being supplied 230 V mains power. Check to see if the line fuse is blown; if it is, identify the reason for the failure and then replace the fuses with others having the same current rating and characteristics.
No manoeuvre is commanded and the OK LED emits 2 fast flashes	The PROG selector is positioned to the left on '1': shift it to the right to '0'
No manoeuvre starts and the flasher is off	Check that the command is actually received: if the command reaches the SbS input, the OK led flashes twice to indicate that the command has been received
The direction of movement is inverted: when an Opening command is imparted, the motor enters the Closing mode.	On the control unit, invert the electrical connections on the motor terminal.
Insert the motor carriage after performing maintenance	<p>Remove the motor carriage from the guide.</p> <p>⚠ To avoid damage to the sliding contacts you must reposition them in their seats. Before inserting the motor carriage into the guide again, do the following:</p> 

8 DISPOSAL OF THE PRODUCT

This product constitutes an integral part of the automation system, therefore it must be disposed of together with the former.

As in installation, also at the end of product lifetime, the disassembly and scrapping operations must be performed by qualified personnel. This product is made up of different types of material, some of which can be recycled while others must be disposed of. Seek information on the recycling and disposal systems envisaged by the local regulations in your area for this product category.

⚠ CAUTION! - Some parts of the product may contain polluting or hazardous substances which, if disposed of into the environment, constitute serious environmental and health risks.



As indicated by the symbol, the product may not be disposed of as domestic waste. Sort the materials for disposal, according to the methods envisaged by current legislation in your area, or return the product to the retailer when purchasing an equivalent product.

⚠ CAUTION! - Local legislation may include the application of serious fines in the event of improper disposal of this product.

9 MAINTENANCE

⚠ CAUTION! - disconnect the power of SPYBOX or SPYBOX B and any backup battery before performing any task on the product. All maintenance operations that require the power supply to the control unit must be performed by a qualified technician.

⚠ CAUTION! - the motor carriage is powered by low voltage through the guide and the insulated metal profile inside it. The use of lubricants such as oil or grease on these two components may degrade the electrical contact and lead to malfunctions. The guide and the profile must not be lubricated around the areas of the sliding contacts.

Clean the guide and the control unit at least once a year

01.	Disconnect the mains power supply and any backup batteries
02.	Clean the guide with a damp cloth
03.	Release the motor carriage and move the door by hand, checking that the motor carriage slides freely in the guide
04.	Check that all the fixing screws are tight
05.	Re-lock the motor carriage to its initial position
06.	Clean the external box of the control unit and the photocell glass lenses (if present) with a damp cloth
07.	After completing the cleaning, connect any backup batteries and provide power

10 TECHNICAL SPECIFICATIONS

⚠ All technical specifications stated herein refer to an ambient temperature of 20° C (± 5° C). • Nice S.p.a. reserves the right to apply modifications to products at any time when deemed necessary, maintaining the same intended use and functionality.

Control unit	SPY550	SPY650	SPY650HS	SPY800 / V1	SPY800
Nominal voltage	230 Vac +/-10%				
Nominal frequency	50/60Hz				
Max. power	200W	250W	300W	250W	300W
Nominal power	120W	150W	190W	150W	190W
Standby power	1.5W	0.5W	0.5W	0.5W	0.5W
Max. current	1.2A	1.4A	1.6A	2.1A	1.6A
Operating temperature	-20°C; +55°C				
Protection class	IP41				
Maximum force	550N	650N	650N	800N	800N
Nominal force	180N	200N	200N	250N	250N
Maximum velocity	0.15 m/s		0.24 m/s	0.14 m/s	
Limits of use	See Chapter 1 and 2 (Table 1 and 2)				
Courtesy light	Integrated to LED				
Preparation for backup battery	No	Yes (mod. PS324)			
Preparation for plug-in radio receiver	No	Yes (mod. SMXI - OXI)			
Preparation for BusT4 connection	Yes Use of optional accessory mod. IBT4N				
Weight	5.3 kg				5.5 kg
Packed size	3240 x 105 x 55 mm	1790 x 130 x 70 mm	1790 x 130 x 70 mm	1790 x 130 x 70 mm	4050 x 105 x 55 mm
Guide					
Type	3.2 m (single profile)	3.2 m (profile in 2 pieces)	3.2 m (profile in 2 pieces)	3.2 m (profile in 2 pieces)	4 m (3.2 + 0.8 m extension)
Mounted rail length	3270 mm	3270 mm	3270 mm	3270 mm	4075 mm
Useful stroke	2700 mm	2700 mm	2700 mm	2700 mm	3500 mm
Weight	5 kg	5.85 kg	5.85 kg	5.85 kg	7.1 kg
Packed size	3240 x 105 x 55 mm	1790 x 130 x 70 mm	1790 x 130 x 70 mm	1790 x 130 x 70 mm	4050 x 105 x 55 mm
Integrated radio receiver					
Type	Incorporated in 4 channels				
Frequency	433.92 MHz				
Coding	Digital Rolling code with 52 Bit FLOR type				
Transmitter compatibility	Family FLOR, ONE, ERA				
Transmitters memorized	100				
Transmitter range	From 10 to 80 m. The range can vary if there are any obstacles or electromagnetic disturbances				

EU Declaration of Conformity and declaration of incorporation of “partly completed machinery”

Note - The content of this declaration corresponds to that specified in the official document deposited at the Nice S.p.A. headquarters and, in particular, to the latest revised edition available prior to the publishing of this manual. The text herein has been re-edited for editorial purposes. A copy of the original declaration can be requested from Nice S.p.A. (TV) I.

Number: 525/SPY	Revision: 3	Language: EN
Manufacturer's Name:	Nice s.p.a.	
Address:	Via Callalta 1, Z.I. Rustignè, 31046 Oderzo (TV) Italy	
Person authorised to compile the technical documentation:	Nice s.p.a.	
Type of product:	Electromechanical gearmotor with separate control unit for the automation of sectional and up-and-over doors	
Model / Type:	SPY550, SPY650, SPY650HS, SPY800, SPYBOX B, SPYBOX	
Accessories:		

The undersigned Roberto Griffa, in the role of Chief Executive Officer, declares under his sole responsibility that the product described above complies with the provisions laid down in the following directives:

- Directive 2014/53/UE (RED) on radio equipment and telecommunications terminal equipment and the mutual recognition of their conformity, in accordance with the following harmonised standards:
 - Health and safety (Art. 3(1)(a)): EN 62479:2010
 - Electrical safety (Art. 3(1)(a)): EN 60950-1:2006+A11:2009+A12:2011+A1:2010+A2:2013
 - Electromagnetic compatibility (Art. 3(1)(b)): EN 301 489-1 V2.2.0:2017, EN 301 489-3 V2.1.1:2017
 - Radio spectrum (Art. 3(3)): EN 300 220-2 V3.2.1:2018

In addition, the product conforms to the following directive in accordance with the provisions applicable to partly completed machinery: (Annex II, part 1, section B):

Directive 2006/42/EC of the EUROPEAN PARLIAMENT AND COUNCIL of 17 May 2006 related to machinery and amending the Directive 95/16/EC (recast).

- I hereby declare that the pertinent technical documentation has been drafted in accordance with Annex VII B of Directive 2006/42/EC and that the following essential requirements have been fulfilled: 1.1.1- 1.1.2- 1.1.3- 1.2.1-1.2.6- 1.5.1-1.5.2- 1.5.5- 1.5.6- 1.5.7- 1.5.8- 1.5.10- 1.5.11
- The manufacturer agrees to send the national authorities any pertinent information on partly-completed machinery, in response to a motivated request, without affecting its intellectual property rights.
- If the partly completed machinery is operated in a European country with an official language other than the language used in this declaration, the importer must include a translation with this declaration.
- The partly completed machinery must not be operated until the final machine in which it is to be incorporated is declared to conform to the provisions of Directive 2006/42/EC, if applicable.

The product also complies with the following standards:

EN 60335-1:2012+A11:2014

EN 60335-2-95:2015+A1:2015, EN 62233:2008, EN 61000-6-2:2005, EN 61000-6-3:2007+A1:2011

Oderzo, 13 marzo 2019

Ing. Roberto Griffa
(Amministratore Delegato)

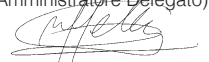

NOTE

A series of horizontal dashed lines for writing notes.

Operation manual (to be given to the final user)

- When you first use the automation, the installation technician must inform you about the origin of the residual risks and you must take time to read the user manual, with special attention to the general warnings (instruction manual).
- Make sure to keep the manual (delivered by the installation technician) for future reference and for handover to any further owner of the automation.
- Your automation system is a machine that will faithfully execute your commands; unreasonable or improper use may generate dangers: do not operate the system if there are people, animals or objects within its range of operation.
- **Children:** automation systems are designed to guarantee high levels of safety and security. They are equipped with detection devices that prevent movement if people or objects are in the way, guaranteeing safe and reliable activation. However, it is advisable to ensure that children do not play in the vicinity of the automation; remote controls should always be kept out of reach. It is not a toy!
- **Checking the system:** in particular all cables, springs and supports to detect possible imbalance, signs of wear or damage.
 - Check on a monthly basis that the gearmotor performs a reverse manoeuvre when the garage door touches an object with a height of 50 mm.
 - Do not use the automation if repairs or adjustments are required; any fault or an incorrectly balanced garage door may lead to physical injury.
- **Malfunctions:** if the automation is malfunctioning, shut off its power supply. Never attempt any repairs; contact your local installer for assistance.
 - The system can be operated manually: release the gearmotor, as described in “Manual release and lock”.
 - Do not modify the system or its programming and adjustment parameters in any way, even if you feel capable of doing it: your installation technician is responsible for the system.
 - The final test, the periodic maintenance operations and any repairs must be documented by the person who has performed them; these documents must remain under the custody of the owner of the system.
- **Disposal:** At the end of the automation’s lifetime, ensure that it is disposed by qualified personnel and that the materials are recycled or scrapped according to current local regulations for this category of product.
- **Control with safety equipment deactivated:** the system can be controlled even if the safety equipment is not operational.

If the flasher flashes several times when a command is given (the number of flashes depends on the cause of the malfunction) but the gate does not respond, proceed as follows:

within 3 seconds, hold down a control; after 2 seconds the movement will start in ‘hold-to-run’ mode and will continue until you release the control.

Important: have the system repaired as soon as possible if the safety equipment is malfunctioning.



‘Transit is allowed only if the gate is open and stationary’.

• Maintenance:

To ensure that no one can activate the garage door, before you begin, remember to lock the automation (as described in “Manual release and lock”) and disconnect all power sources.

In order to ensure constant levels of safety and the maximum useful life of the automation, it must undergo programmed maintenance work every 6 months.

⚠ CAUTION! – The maintenance operations must be performed in strict compliance with the safety directions provided in this manual and according to applicable legislation and standards.

01.	OFF 	+ any backup batteries present
02.	Check for any deterioration in automation system components, paying special attention to erosion or oxidation of the structural parts. Replace any parts which are below the required standard.	
03.	Check the wear and tear of the moving parts.	
04.	Clean the rail and strip with a dry cloth to remove any dirt.	
05.	ON 	Run all the tests and checks indicated in par. 4.1 - Testing.

• Manual release and lock of the gearmotor

01.	pull down the appropriate cord until you hear a double click
-----	--

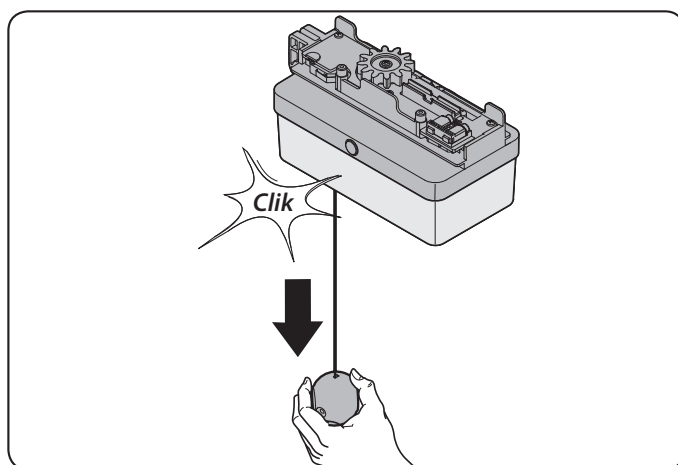

NOTE

A series of horizontal dashed lines for writing notes.

NOTE

A series of horizontal dashed lines for writing notes.



Nice SpA
Oderzo TV Italy
info@niceforyou.com

www.niceforyou.com